

## Important Before You Start

This is a quick set-up guide only. Please read supplied **(Instructions For Use)** manual carefully and completely before using this product. As with any device, failure to carefully read and follow all instructions and safety information prior to use may result in decreased product performance or failure. See Dabir Operation Instructions for system operation.

## Dabir Surface Installation

1. Place Surface flat onto patient support surface, mattress or pad with “THIS SIDE UP” facing up (gray side down) and secure corner straps when applicable. Hose routing is preferred at the foot end for bed installations.
2. Place facility supplied cover sheet and incontinence pad over the top of the Surface and tuck edges underneath the mattress or pad. Avoid wrinkles whenever possible to optimize performance and patient comfort.

## MedSurg Bed / Gurney Installation

Place cover sheet and incontinence pad **ABOVE** Dabir Surface.

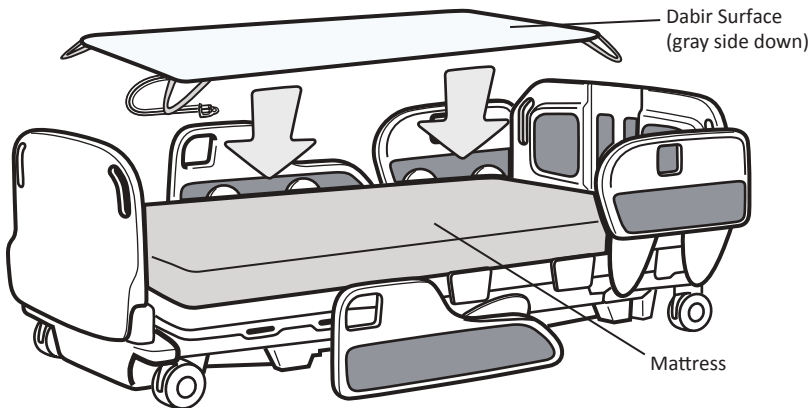

## Surgical Table Installation

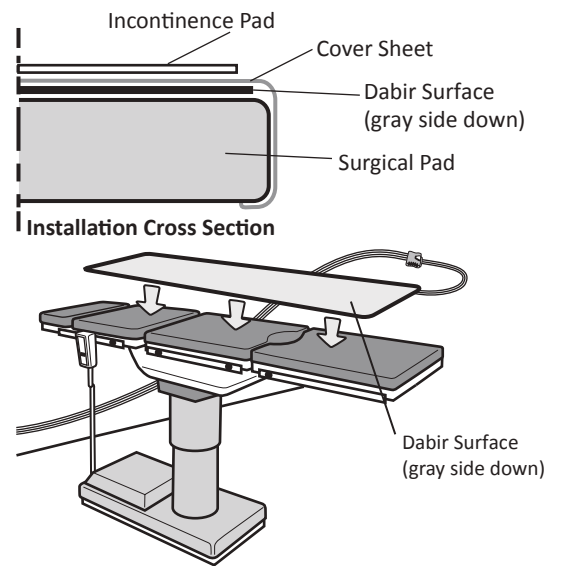

## Hose/Surface Connection

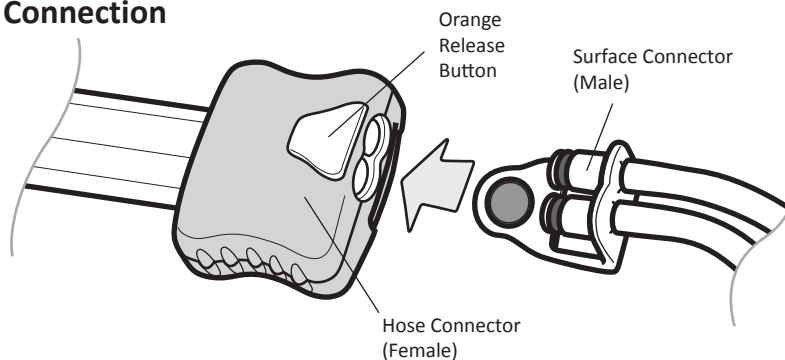

**CAUTION:** Do not use petroleum based lubricants on seals as it may cause them to swell and/or leak

## Connection Procedure

Insert the Surface Connector into the Hose Connector. An audible “click” can be heard once the Connectors are fully seated. Confirm Connector seating with a slight pull.

## Disconnection Procedure

Depress the Orange Button and pull Surface Connector to release.

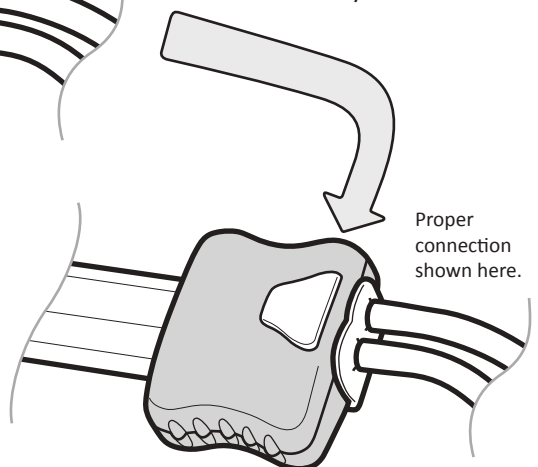



## Operation and Settings

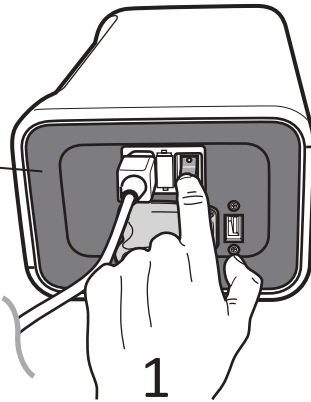

### To operate the Dabir System:

1. Power Controller "ON" by depressing the Main Toggle Switch located on the side of the unit.
2. Touch the "START/STOP"  Key to activate Surface Cycling.
3. Touch the desired Cycle Speed and Firmness Settings.



 FLASHING GREEN KEY = SYSTEM PAUSED  
 SOLID GREEN KEY = SYSTEM ACTIVATED

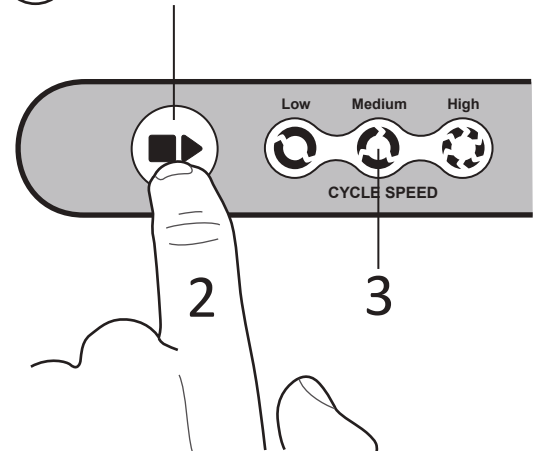

**NOTE:** Power "ON" will automatically "START" session in 30 seconds.

## Cleaning Procedures

The cleaning procedures listed below are recommended by the manufacturer and should be adjusted according to specific healthcare facility policy. Aggressive cleaning measures may cause damage and it is the responsibility of the caregiver to replace surfaces when needed.

### Cleaning the Dabir Surface:

With the Surface connected to the Hose, disinfect by wiping down all areas with a hospital grade disinfecting cleaner and water, making sure to remove any organic debris. Allow for proper drying time per the disinfectant manufacturer's instructions.

Cleaner residue may affect the Surface slip resistance. If this occurs, wipe the Surface with a water moistened cloth to remove any residue.

For a list of approved and unapproved cleaners, visit: [www.dabir-surfaces.com/cleaners](http://www.dabir-surfaces.com/cleaners)

### NOTES AND SAFETY WARNINGS:

- Surfaces are intended to be used above an underlying support mattress or pad with good redistribution properties.
- Surfaces are not to be used in direct contact with patient skin. (Always cover with bed sheet.)
- Always make sure the Device is powered "ON" and that the Surface is activated during intended patient use.
- It is the responsibility of the caregiver to ensure that the user can operate this product safely.
- It is the responsibility of the caregiver to adequately secure and protect against patient falls.
- It is the responsibility of the caregiver that the device is properly cleaned prior to patient use.
- It is the responsibility of the caregiver to properly dispose of the Surface when damage or contamination occurs.
- Always turn Device "OFF" during patient transfer, cleaning and before patient positioning.
- No Latex is used in the manufacturing of this product.



**Headquarters and Manufacturer:** Dabir Surfaces, Inc., 7447 West Wilson Ave., Harwood Heights, IL 60706, USA Tel: +1(888)559-3641  
**Sales:** sales@dabir-surfaces.com  
**Technical and Warranty Support:** support@dabir-surfaces.com Tel: +1(888)559-3642  
**Website:** www.dabir-surfaces.com  
**Distributor (North America):** STERIS Corporation, Customer Service, Tel: +1(800)548-4873, Fax: +1(400)639-4450; Service Support, Tel: +1(800)333-8828  
**European Authorized Representative:** Emergo Europe, Westervoortsedijk 60, 6827 AT Arnhem, The Netherlands

