

Technology to the next degree™



ELECTRI-COOL® II

OPERATION AND TECHNICAL MANUAL

Model 767 Localized Cooling System

Gentherm Customer Relations

Gentherm Medical, LLC

| | |
|---------------------------|--|
| Telephone | 1-513-772-8810 |
| Toll-Free | 1-800-989-7373 |
| Fax | 1-513-772-9119 |
| 24-Hour Clinical Support | 1-513-460-2038 |
| Medical Technical Support | 1-888-437-5608 |
| Email | medical@gentherm.com |
| <u>Website:</u> | https://www.gentherm.com |
| Mailing Address: |  12011 Mosteller Road Cincinnati OH 45241 USA |

Electri-Cool® II is a registered trademark of Gentherm Medical, LLC, Cincinnati, Ohio, USA.

© 2021, Gentherm Medical, LLC All rights reserved.

All other trademarks are the property of their respective owners.

Part No. 56269 Rev. W

Contents

| | | |
|-------------|--|-----------|
| 1.0 | Introduction | 1 |
| 1.1 | Receiving and Inspection/ Important Safety Information | 1 |
| 1.2 | General Safety Precautions | 1 |
| 1.3 | General Product Description | 1 |
| 1.4 | Indications for Use | 2 |
| 1.5 | Contraindications | 2 |
| 1.6 | Transporting and Shipping | 2 |
| 2.0 | General Safety Precautions | 2 |
| 3.0 | Warnings | 3 |
| 4.0 | Cautions | 3 |
| 5.0 | Symbols on the Device and in the Manual | 5 |
| 6.0 | Serial Number | 7 |
| 7.0 | Warranty | 7 |
| 7.1 | Receiving Inspection and Setup | 7 |
| 8.0 | Technical Help | 7 |
| 9.0 | Authorized European Representative | 7 |
| 10.0 | Introduction | 8 |
| 10.1 | Before you call for service..... | 8 |
| 11.0 | Setup | 9 |
| 11.1 | Equipment Set-Up | 9 |
| 11.2 | Mounting the unit to a bed bracket | 9 |
| 11.3 | Reservoir Filling Instructions | 10 |
| 11.4 | Startup Instructions | 10 |
| 11.5 | Setting Temperature | 10 |
| 11.6 | Accessories | 12 |
| 11.7 | Pad Instructions | 13 |
| 11.8 | Disposal | 13 |
| 11.9 | Cleaning (External) | 13 |
| 11.10 | Storage | 14 |
| 12.0 | Electromagnetic Emissions | 14 |
| 13.0 | Maintenance | 18 |
| 13.1 | Overview | 18 |

Gentherm Medical, LLC

| | | |
|-------------|--|-----------|
| 13.2 | Inspection Frequency | 18 |
| 13.3 | Exterior Physical Inspection & Cleaning..... | 18 |
| 13.4 | Draining the Reservoir..... | 18 |
| 14.0 | Air Filter Inspection and Replacement..... | 19 |
| 14.1 | Remove the Filter Retainer | 20 |
| 15.0 | Draining the Reservoir | 22 |
| 16.0 | Troubleshooting Guide..... | 24 |
| 16.1 | General | 24 |
| 16.2 | Indicator Specifics | 25 |
| 17.0 | Service | 26 |
| 18.0 | ECII Interior Access..... | 27 |
| 18.1 | Flow Test..... | 28 |
| 18.2 | Water Leak Test | 28 |
| 18.3 | Temperature Test | 28 |
| 18.4 | Low Water Switch/Indicator Test | 29 |
| 18.5 | Leakage Current Test | 30 |
| 18.6 | Ground Continuity Test | 30 |
| 18.7 | Water Temperature Low-Limit Thermistor Test..... | 30 |
| 18.8 | Internal Physical Inspection | 31 |
| 19.0 | Preventive Maintenance for Service Personnel..... | 33 |
| 20.0 | Rear Enclosure and Reservoir Lid Replacement..... | 38 |
| 20.1 | Rear Enclosure and Reservoir Lid Removal | 39 |
| 20.2 | Rear Enclosure and Reservoir Lid Installation | 41 |
| 21.0 | Front Enclosure Replacement..... | 43 |
| 21.1 | Front Enclosure Removal | 44 |
| 21.2 | Front Enclosure Installation | 45 |
| 22.0 | Bottom Enclosure Replacement | 47 |
| 22.1 | Bottom Enclosure Removal | 48 |
| 22.2 | Bottom Enclosure Installation | 49 |
| 23.0 | Equipotential Grounding Stud Replacement | 50 |
| 23.1 | Grounding Stud Removal | 50 |
| 23.2 | Grounding Stud Installation | 51 |
| 24.0 | Membrane Panel Replacement | 53 |
| 24.1 | Membrane Panel Removal | 54 |
| 24.2 | Membrane Panel Installation..... | 55 |

| | | |
|-------------|---|------------|
| 25.0 | Float Switch Replacement | 56 |
| 25.1 | Float Switch Removal | 57 |
| 25.2 | Float Switch Installation | 58 |
| 26.0 | Reservoir Replacement | 61 |
| 26.1 | Reservoir Removal | 62 |
| 26.2 | Reservoir Installation | 63 |
| 27.0 | Pump Replacement | 64 |
| 27.1 | Pump Removal | 65 |
| 27.2 | Pump Installation | 68 |
| 28.0 | Quick Disconnect Panel Mount Couplings Replacement | 71 |
| 28.1 | Quick Disconnect Removal | 72 |
| 28.2 | Quick Disconnect Installation | 74 |
| 29.0 | Fuse Replacement | 77 |
| 29.1 | Fuse Removal | 78 |
| 29.2 | Fuse Installation | 79 |
| 30.0 | Power Inlet and Wire Harness Replacement | 80 |
| 30.1 | Power Inlet Removal | 81 |
| 30.2 | Power inlet Installation | 84 |
| 31.0 | Control Board Replacement | 87 |
| 31.1 | Control Board Removal | 88 |
| 31.2 | Control Board Installation | 89 |
| 32.0 | Power Supply Replacement | 90 |
| 32.1 | Power Supply Removal | 91 |
| 32.2 | Power Supply Installation | 93 |
| 33.0 | Thermoelectric (TE) Module Replacement | 96 |
| 33.1 | TE Module Removal | 97 |
| 33.2 | TE Module Installation | 99 |
| 34.0 | Fan Motor Replacement | 101 |
| 34.1 | Fan Motor Removal | 102 |
| 34.2 | Fan Motor Installation | 103 |
| 35.0 | Fan Guard Replacement | 106 |
| 35.1 | Fan Guard Removal | 107 |
| 35.2 | Fan Guard Installation | 110 |
| 36.0 | Specifications | 113 |
| 36.1 | Expected Service Life | 114 |
| 36.2 | Replacement Parts | 118 |

Gentherm Medical, LLC

| | | |
|-------------|---|------------|
| 37.0 | Fluid Circuit Disinfection/Dry Storage Procedure | 122 |
| 37.1 | Draining the Electri-Cool II | 122 |
| 37.2 | Chemical Cleaning Circulation Chart | 122 |
| 37.2.1 | Disinfection/Dry Storage Procedure..... | 122 |
| 38.0 | Appendix A | 124 |
| 39.0 | Approvals | 125 |
| 39.1 | General Safety and Electrical Safety..... | 125 |

List of Figures

| | | |
|------------------|---|----|
| Figure 1 | Mounting the unit to a bed bracket | 9 |
| Figure 2 | Mounting the bed bracket to rear enclosure | 9 |
| Figure 3 | Electri-Cool II Membrane Control Panel | 11 |
| Figure 4 | Step 1 Unplug power cord | 20 |
| Figure 5 | Step 2 Pry off retainer | 20 |
| Figure 6 | Step 3 Discard used filter | 20 |
| Figure 7 | Step 4 Place filter in retainer | 21 |
| Figure 8 | Step 5 Align tabs to slots | 21 |
| Figure 9 | Step 6 Press retainer into place | 21 |
| Figure 10 | Step 1 Unplug power from mains | 22 |
| Figure 11 | Step 3 Open reservoir lid | 22 |
| Figure 12 | Step 4 Tip unit forward | 22 |
| Figure 13 | Control board diagram | 32 |
| Figure 14 | Detail A Operate Position | 32 |
| Figure 15 | Detail A Test Position | 32 |
| Figure 16 | Exploded view with callouts | 35 |
| Figure 17 | Step 1 Unplug power cord | 39 |
| Figure 18 | Step 3 Remove two handle screws | 39 |
| Figure 19 | Step 4 Remove two base screws | 39 |
| Figure 20 | Step 5 Remove collar | 40 |
| Figure 21 | Step 6 Lift rear enclosure with lid up and away | 40 |
| Figure 22 | Step 1 Install enclosure and lid | 41 |
| Figure 23 | Step 2 Install reservoir collar | 41 |
| Figure 24 | Step 3 Install two base enclosure screws | 41 |
| Figure 25 | Step 4 Install two handle screws | 42 |
| Figure 26 | Step 2 Remove four screws | 44 |
| Figure 27 | Step 4 Remove front enclosure | 44 |
| Figure 28 | Step 5 Disconnect ribbon cable | 44 |
| Figure 29 | Step 3 Install front enclosure | 45 |

Gentherm Medical, LLC

| | | |
|------------------|--|----|
| Figure 30 | Step 5 Reconnect ribbon cable. | 45 |
| Figure 31 | Step 5 Install front enclosure. | 46 |
| Figure 32 | Step 5 Remove rubber feet | 48 |
| Figure 33 | Step 1 Install feet | 49 |
| Figure 34 | Step 2 Apply the BF label. | 49 |
| Figure 35 | Step 3 Apply the GTIN label. | 49 |
| Figure 36 | Step 1 Remove 1st Keps nut | 50 |
| Figure 37 | Step 2 Remove ground wire and second Keps nut | 50 |
| Figure 38 | Step 1 Insert stud | 51 |
| Figure 39 | Step 2 Add the green and gold ring | 51 |
| Figure 40 | Step 3 Install Keps nuts 1 & 2. | 52 |
| Figure 41 | Step 5 Attach ground wire and second Keps nut | 52 |
| Figure 42 | Step 3 Unplug ribbon cable | 54 |
| Figure 43 | Step 4 Push flat screwdriver through cable slot from the inside | 54 |
| Figure 44 | Step 1 Thread cable through slot. | 55 |
| Figure 45 | Step 4 Connect ribbon cable | 55 |
| Figure 46 | Step 3 Disconnect J7 | 57 |
| Figure 47 | Step 4 Loosen reservoir insulation | 57 |
| Figure 48 | Step 5 Unscrew float switch mounting nut | 57 |
| Figure 49 | Step 1 GEMS orientation | 58 |
| Figure 50 | Step 2 Thread wires through gasket | 58 |
| Figure 51 | Thread connector and wires through reservoir | 58 |
| Figure 52 | Step 4 Secure float switch mounting nut. | 59 |
| Figure 53 | Step 5 Loosen reservoir insulation | 59 |
| Figure 54 | Step 6 Route wiring behind bracket | 59 |
| Figure 55 | Step 7 Attach connector to J7. | 60 |
| Figure 56 | Step 5 Loosen two hose clamps | 62 |
| Figure 57 | Step 6 Remove tubing. | 62 |
| Figure 58 | Step 1 connect tubing to reservoir with clamps | 63 |
| Figure 59 | Step 3 Float switch wires position. | 63 |
| Figure 60 | Step 4 Connect float switch to J7. | 63 |

| | | |
|------------------|---|----|
| Figure 61 | Step 3 Unplug pump wiring | 65 |
| Figure 62 | Step 4 Remove the wire tie | 65 |
| Figure 63 | Step 5 Remove EMI suppressor | 65 |
| Figure 64 | Step 7 Remove discharge tubing | 66 |
| Figure 65 | Step 5 Loosen two hose clamps | 66 |
| Figure 66 | Step 6 Unscrew pump bracket from base enclosure | 66 |
| Figure 67 | Step 8 Remove inlet tubing | 67 |
| Figure 68 | Step 1 Remove pump from bracket | 67 |
| Figure 69 | Step 1 Mount pump to bracket | 68 |
| Figure 70 | Step 2 Mount bracket to base | 68 |
| Figure 71 | Step 3 slide tubing onto new pump | 68 |
| Figure 72 | Step 4 Tighten the hose clamps | 69 |
| Figure 73 | Step 5 Install EMI suppressor | 69 |
| Figure 74 | Step 6 Wire tie below EMI suppressor | 69 |
| Figure 75 | Step 7 Secure wires to bracket | 70 |
| Figure 76 | Step 8 Route wires behind bracket | 70 |
| Figure 77 | Step 9 Connect power wire connector to J5 | 70 |
| Figure 78 | Step 4 Tubing at 90 degree elbow | 72 |
| Figure 79 | Step 5 Remove tubing from pump | 72 |
| Figure 80 | Step 6 Slide retainer nuts up | 73 |
| Figure 81 | Step 7 Pull couplings out of enclosure | 73 |
| Figure 82 | Slide retainer nuts onto tubing | 74 |
| Figure 83 | Step 6 Extend tubing through enclosure | 74 |
| Figure 84 | Step 7 Insert couplings into hose | 75 |
| Figure 85 | Step 8 Turn and align couplings | 75 |
| Figure 86 | Step 9 Tighten retaining nuts | 76 |
| Figure 87 | Step 11 Tape the exposed clamps | 76 |
| Figure 88 | Step 12 Apply electrical tape around insulation | 76 |
| Figure 89 | Step 1 Unplug power | 78 |
| Figure 90 | Step 2 Open fuse door | 78 |
| Figure 91 | Step 3 Note direction arrows | 78 |

Gentherm Medical, LLC

| | | |
|-------------------|--|----|
| Figure 92 | Step 1 Place fuses into holders | 79 |
| Figure 93 | Step 2 Match arrow direction | 79 |
| Figure 94 | Step 3 Locking tabs | 79 |
| Figure 95 | Step 3 Plastic power inlet shroud | 81 |
| Figure 96 | Step 4 Remove retaining Keps nut and ground wires | 81 |
| Figure 97 | Step 5 Disconnect harness from the power supply | 82 |
| Figure 98 | Step 6 Remove suppressor. | 82 |
| Figure 99 | Step 7 Remove retaining screws | 83 |
| Figure 100 | Step 8 Power inlet removal 2 | 83 |
| Figure 101 | Step 2 Install power inlet | 84 |
| Figure 102 | Step 3 Connect control board wires to J2 | 84 |
| Figure 103 | Step 4 Install EMI suppressor | 84 |
| Figure 104 | Step 5 Route wire harness connector behind bracket. | 85 |
| Figure 105 | Step 6 Connect power supply | 85 |
| Figure 106 | Step 7 Attach all grounding wires | 85 |
| Figure 107 | Step 8 Reinstall plastic power inlet shroud. | 86 |
| Figure 108 | Step 3 Disconnect all 5 connectors. | 88 |
| Figure 109 | Step 4 Remove three plastic screws | 88 |
| Figure 110 | Step 5 Remove three plastic washers (one shown) | 88 |
| Figure 111 | Step 1 Remove three plastic washers (one shown) | 89 |
| Figure 112 | Step 2 Reinstall three plastic screws | 89 |
| Figure 113 | Step 3 Connect all 5 connectors | 89 |
| Figure 114 | Step 4 Unscrew power supply from front bracket | 91 |
| Figure 115 | Step 5 Control board power wire harness | 91 |
| Figure 116 | Step 6 Remove Phillips screws from rear bracket. | 92 |
| Figure 117 | Step 7 Disconnect power supply wires to power inlet | 92 |
| Figure 118 | Step 8 Remove wire tie on power supply. | 92 |
| Figure 119 | Step 1 Connect power supply wires from power inlet | 93 |
| Figure 120 | Step 2 Install two truss-head screws on rear bracket | 93 |
| Figure 121 | Step 3 Connect fan wires to the power supply | 93 |
| Figure 122 | Step 4 Detail | 94 |

Figure 123 Step 5 Power supply wires placement 94

Figure 124 Step 6 Secure power supply wires to front bracket 94

Figure 125 Step 7 Wire tie the harness to the third slot. 95

Figure 126 Step 5 Remove screws and plastic spacers. 97

Figure 127 Step 6 Remove two screws attaching the TE module to the back bracket . . . 97

Figure 128 Step 7 Remove tubing from TE module. 98

Figure 129 Step 1 Reconnect TE tubing 99

Figure 130 Step 2 Install 2 screws attaching TE module to the front bracket 99

Figure 131 Step 3 Install 2 screws and spacers 99

Figure 132 Step 7 Remove the fan 102

Figure 133 Step 8 Remove brackets 102

Figure 134 Step 1 Install four screws into fan guard holes 103

Figure 135 Step 2 Place filter into retainer 103

Figure 136 Step 3 Re-attach filter retainer 103

Figure 137 Step 4 Raise up off table. 104

Figure 138 Step 5 Install brackets. 104

Figure 139 Step 6 Place fan over TE brackets on fan guard screws 104

Figure 140 Step 7 Wire position 105

Figure 141 Step 3 Pry filter cover off. 107

Figure 142 Step 4 Remove shield 107

Figure 143 Step 5 Unscrew four screws 107

Figure 144 Step 6 Remove Keps nut #1 108

Figure 145 Step 7 Remove Keps nut #2. 108

Figure 146 Step 8 Remove Keps nut #3. 108

Figure 147 Step 9 Remove Keps nut #4. 109

Figure 148 Step 1 Insert screws in order. 110

Figure 149 Step 3 Hold Keps nut #3. 110

Figure 150 Step 4 Insert screw #4. 110

Figure 151 Step 5 Hold Keps nut #4. 111

Figure 152 Step 6 Place plastic shield in position 111

Gentherm Medical, LLC

| | | |
|-------------------|---|-----|
| Figure 153 | Step 2 Place filter into retainer | 111 |
| Figure 154 | Step 8 Re-attach filter retianer | 112 |
| Figure 155 | Exploded view | 120 |
| Figure 156 | Wiring Schematic | 121 |

List of Tables

- Table 1** Device and Manual Symbols 5
- Table 2** Presented in Fulfillment of IEC 60601-1-2 14
- Table 3** Electromagnetic Immunity 15
- Table 4** Troubleshooting 24
- Table 5** Preventive Maintenance Inspection Sheet 33
- Table 6** Parts List 36
- Table 7** Temperature Equivalent for Resistances at Control & Low Temp Thermistor124

This page intentionally left blank.

1.0 Introduction



Use this manual for service and repair information. Read and understand all precautions before servicing the device.

1.1 Receiving and Inspection/ Important Safety Information

After unpacking the Electri-Cool® II, inspect the system for concealed damage. Retain all packing material and carefully record or photograph any damage. Notify the carrier at once and ask for an inspection (in writing). Failure to do this within 15 days may result in loss of claim. Do not return the equipment to Gentherm. Call our Medical Technical Service department for further instruction.

1.2 General Safety Precautions

To provide the patient with maximum safety during the use of the Electri-Cool® II Cold Therapy system, a thorough knowledge and understanding of the system, and its correct application and operating use are required. Each person who is responsible for use or direction of use of the system, such as physicians, nurses, technicians and operators, must read and understand this operation and technical manual as well as all precautions and warnings prior to use.

Gentherm recommends reading this manual at least semi-annually for safe operation and application. In-service training is available upon request.

This manual may not be reproduced in whole or in part without written permission from Gentherm Medical, LLC.

Gentherm Medical, LLC reserves the right to make changes to the Electri-Cool II that might not be reflected in this manual. Current manuals are available on the website: <https://www.gentherm.com>

1.3 General Product Description

The Electri-Cool® II system has been designed to provide maximum thermal transfer efficiency at optimum safety. The Electri-Cool® II consists of a plastic reservoir for holding sterile water or water that has been passed through a filter less than or equal to 0.22 microns; a float switch to sense water level; a pump for circulating water through an external pad; a thermoelectric (TE) module to cool the water; a microprocessor-based electronic control to regulate water temperature; and a fan to transfer absorbed heat to the ambient air. The user can select among three pre-set temperature ranges: 51°F - 55°F (11°C - 13°C); 46°F - 50°F (8°C - 10°C); and 40°F - 45°F (5°C - 7°C). In addition to the aforementioned features, this model includes audible and visual indicators for low temperature and low water levels. The unit also shuts down entirely in the event of an internal component over-temperature condition.

Operation & Service Manual

1.4 Indications for Use

The Electri-Cool® II, Model 767 Portable Cold Therapy Unit is used to provide cold therapy immediately following the surgical procedure at the wound site. The system is composed of a water reservoir, a thermoelectric sub-assembly, a circulating pump, a micro-processor control board, a fan and a local therapy pad.

1.5 Contraindications

There are currently no known contraindications.

1.6 Transporting and Shipping

Drain all water from the reservoir before shipment or storage. The Electri-Cool® II can be transported through normal shipping methods via ground, air, or water when packaged in its approved packaging material. During transportation and storage, packaging should not be exposed to conditions that fall out of the ranges below:

Temperature: -40°C to 70°C (-40°F to 158°F)

Humidity: 10% to 100%

Atmospheric Pressure: 500 to 1060hPa (7.25 to 15.37 PSIA)

Receiving Inspection

After unpacking the ELECTRI-COOL II System, be sure to inspect the components for concealed damage. Retain all packing material and carefully describe or photograph any damage. Notify the carrier at once and ask for an inspection (in writing). Failure to do this within 15 days may result in loss of claim. Do not return the equipment to Gentherm. Call our Medical Technical Service department for further instructions.

2.0 General Safety Precautions

To provide the patient with maximum safety during the use of the Electri-Cool® II Cold Therapy system, a thorough knowledge and understanding of the system, and its correct application and operating use are required. Each person who is responsible for use or direction of use of the system, such as physicians, nurses, technicians and operators, must read and understand this operation and technical manual as well as all precautions and warnings prior to use.

3.0 Warnings



Gentherm Medical, LLC, reserves the right to make equipment changes and improvements, which may not be reflected in this manual.

- A physician's order is required for setting temperature and use of equipment. At least every 20 minutes, or as directed by a physician, check the patient's temperature and skin condition of areas in contact with the pad. Also check pad water temperature. Pediatric, temperature-sensitive patients with vascular disease, surgical patients, diabetics and patients with Raynaud's Disease should be checked more frequently. **Notify the physician promptly of any change, in order to avoid serious injury.**
- **Observe patient's skin condition frequently due to individual differences in sensitivity and susceptibility to injury from cold and/or externally applied chemicals or pressure. Patients at greatest risk are those unconscious, on prolonged therapy, diabetics, children and persons incapacitated or with insensitive skin areas or poor circulation.**
- Prevent excessive and/or prolonged tissue pressure and shearing forces, especially over bony prominences **to prevent skin damage which may result.**
- Do not place additional heat or cold sources between the patient and pad. **Skin damage may occur.**
- The area between the patient and the pad should be kept dry **to avoid injury to the patient.**
- Do not use pins to secure pad or hoses. Do not allow pad or hoses to come in contact with any sharp object. **A water leak could cause a slip hazard.**
- Do not use the Electri-Cool II system in the presence of flammable anesthetics. **Risk of explosion can result.**
- Power interruption will cause the Electri-Cool II system to revert to the default range of 40°F - 45°F (5°C - 7°C). Follow instructions for section 11.4 Startup Instructions, on page 10 to resume operation. **Failure to resume the desired therapy could result in injury.**
- In order to avoid the **risk of electric shock**, this equipment must only be connected to a supply main with protective earth.
- **Electric shock hazard may be present. Do not remove cover. Service is to be performed by qualified personnel only.**

4.0 Cautions













- US Federal Law restricts this device to sale by or on the order of a physician.
- Use sterile water or water that has been passed through a filter less than or equal to 0.22 microns only. Do not use De-ionized water. De-ionized water may cause corrosion to plumbing system components. Do not use tap water or distilled water.

Operation & Service Manual

- **Do not** use alcohol. Alcohol may cause pad and unit deterioration.
- **Do not** overfill. Overfilling may result in overflow when the water in the pad drains back into the system when it is turned off.
- Use only hospital grade power plug, or electrical shock may result.
- Check hose couplings to be certain that they are properly locked together.
- Make sure hose and pads are free of kinks which might restrict flow.
- Complete folding of pad may restrict flow and reduce therapy to patient.
- The pad surface should be checked for damage prior to each application.
- To ensure maximum therapy is delivered, it may be necessary to retain the pad on the patient with straps for adequate contact with the patient.
- Follow pad instructions as well as hospital/physician instructions for applying, storing and disposal of product.
- Special precautions regarding electromagnetic compatibility are required and the Electri-Cool II needs to be installed and put into service according to the electromagnetic compatibility information provided. Electromagnetic compatibility refers to electronic devices unintentionally affecting the operation of each other by emitting electromagnetic energy.
- Due to electromagnetic compatibility, other equipment can affect the Electri-Cool II system. The Electri-Cool II should not be used adjacent to or stacked with other equipment. Other equipment includes ventilators, patient monitors, anesthesia delivery equipment, etc. If adjacent placement or stacking is necessary, the Electri-Cool II and the other equipment should be observed to verify that it is operating normally in the mode that is set.
- If the Electri-Cool II system or other equipment is not operating normally, remove the device from service and have a biomedical or service technician observe the device in operation. Refer to the specifications section for recommended separation distances between other equipment and the Electri-Cool II system.
- For safe handling and use of chemicals, follow manufacturer guidelines for cleaning.
- Always drain the Electri-Cool II to a sanitary drain because bio-contaminants may be present in the unit's water supply.





5.0 Symbols on the Device and in the Manual

Table 1. Device and Manual Symbols

| Symbol | Definition |
|--|-------------------------------------|
| I/O | On / Off |
|  | Read and Understand the Manual |
|  | Warning |
|  | Inspect and Change Filter Regularly |
|  | Low Water Level |
|  | Caution |
| 2°C/36°F  | Low Water Temperature |
|  | Type B Applied Part |
|  | Temperature Settings |
|  | Alternating Current |
|  | Externally Accessible Fuse |

Operation & Service Manual

Table 1. Device and Manual Symbols

| Symbol | Definition |
|---|--|
|  | Potential Equalization Connection (Grounding) |
|  | Risk of Explosion: Do not use in the presence of flammable anesthetics |
|  | Power On (Located on Switch) |
|  | Power Off (Located on Switch) |
|  | Separate Disposal for Electrical Equipment |

6.0 Serial Number

The serial number is located on the specifications label on the side of the device. The serial number encodes information about the manufacture of your system. For example, the serial number 201-767-6123 indicates the following:

- 20 Year of Manufacture
- 1 Quarter of the Manufacture year, in this case, first quarter
- 767 Model number; for this example, it is 767
- 6123 Manufactured device number

Record the serial number of your system and have it ready if you call for service.

7.0 Warranty

All parts are covered by a one (1) year warranty. Additional warranties are available at time of purchase or during the warranty period. If a part requires replacement while under warranty, return the original part to Gentherm. Labor is covered under the warranty only if the device is returned to Gentherm. If the part is no longer under warranty, dispose of the part as required by site or local regulations.

7.1 Receiving Inspection and Setup

After unpacking the Electri-Cool II system, be sure to inspect the system for concealed damage. Retain all packing material and carefully describe or photograph any damage. Notify the carrier at once and ask for an inspection (in writing). Failure to do this within 15 days may result in loss of claim. Do not return the equipment to Gentherm. Call our Medical Technical Service department for further instructions.

8.0 Technical Help

24-Hour Clinical Support 1-513-460-2038

Medical Technical Support 1-888-437-5608

Report any serious incident in relation to the device to the manufacturer and to the competent authority of the Member State in which the user or patient is established.



European Representative

CEpartner4U BV
Esdoornlaan 13
3951 DB Maarn
The Netherlands
www.CEpartner4u.com

10.0 Introduction

10.1 Before you call for service....

To help us better serve you, please have the serial number of your Electri-Cool® II unit ready when you call for parts or service. The serial number is located on the unit's rear panel.

11.0 Setup

11.1 Equipment Set-Up

1. Before use, check the air filter for accumulated dust. If filter is dirty, replace it with a new one. Refer to section 14.0 Air Filter Inspection and Replacement, on page 19.
2. Check to ensure that the water level in the reservoir is at its maximum level. The maximum level is at the lowest level of the fill spout (or threaded neck). Refer to section 11.3 Reservoir Filling Instructions, on page 10.



Caution: This product uses sterile water or water that has been passed through a filter less than or equal to 0.22 microns only. Do not use de-ionized water or distilled water. De-ionized water may cause corrosion to plumbing system components. Do not use tap water. Minerals and deposits can clog plumbing system components. All references throughout this document to water or sterile water are restricted to this definition.

3. The Electri-Cool II should be placed on a secure, flat surface at least 61cm (2 feet) from any wall or object that may restrict airflow to the unit. A bed bracket or universal stand as listed in “Accessories” section can also be used within proximity of the patient so that the attached hoses will reach the desired therapy site.

11.2 Mounting the unit to a bed bracket

Note: (Bed bracket accessories are sold separately.)

1. Position the bed bracket so that the two holes (A) align with the holes in the back of the unit (B) (Figure 1) and (Figure 2).
2. Insert the thumbscrews and hand-tighten.



Figure 1 - Mounting the unit to a bed bracket

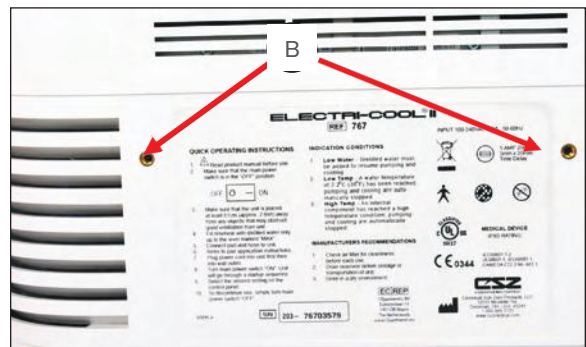

Figure 2 - Mounting the bed bracket to rear enclosure

Operation & Service Manual

11.3 Reservoir Filling Instructions



CAUTION: This product uses sterile water or water that has been passed through a filter less than or equal to 0.22 microns only. Do not use de-ionized water or distilled water. De-ionized water may cause corrosion to plumbing system components. Do not use tap water. Minerals and deposits can clog plumbing system components. All references throughout this document to water or sterile water are restricted to this definition.

1. Lift the reservoir lid and fill the reservoir with sterile water or water that has been passed through a filter less than or equal to 0.22 microns to its maximum level. The maximum level is at the lowest level of the fill spout (or threaded neck). Close the lid.

Note: Optimum operation is obtained when water level is well above the low water level marked “MIN”. The low water cut-off switch will activate before the water level reaches the bottom of the window.

11.4 Startup Instructions

1. Plug the power cord into a grounded receptacle providing the proper voltage and frequency.
2. Press the power switch to the “ON” position. Electri-Cool II will then begin a startup sequence for approximately one (1) minute. During this sequence, check to make sure that all audible and all five (5) visual indicators are working. Check that there is water flow through the pad. Check water level and refill with cool sterile water or water that has been passed through a filter less than or equal to 0.22 microns if necessary.
3. The Electri-Cool II is now ready for use.

11.5 Setting Temperature

1. The Electri-Cool II must be filled with sterile water or water that has been passed through a filter less than or equal to 0.22 microns and connected to a pad before attempting to set temperature.
2. Select a temperature range among the three possible settings:
 - 11°C - 13°C (51°F - 55°F)
 - 8°C - 10°C (46°F - 50°F)
 - 5°C - 7°C (40°F - 45°F)

- 3. A visual light (green temperature indicating LED) located near the upper-left area of the selected button will indicate the selected range. Allow fifteen to twenty minutes for the water to reach selected temperature. The time required for the unit to reach the set point depends on the pad used and the ambient temperature. The time may also vary from patient to patient.

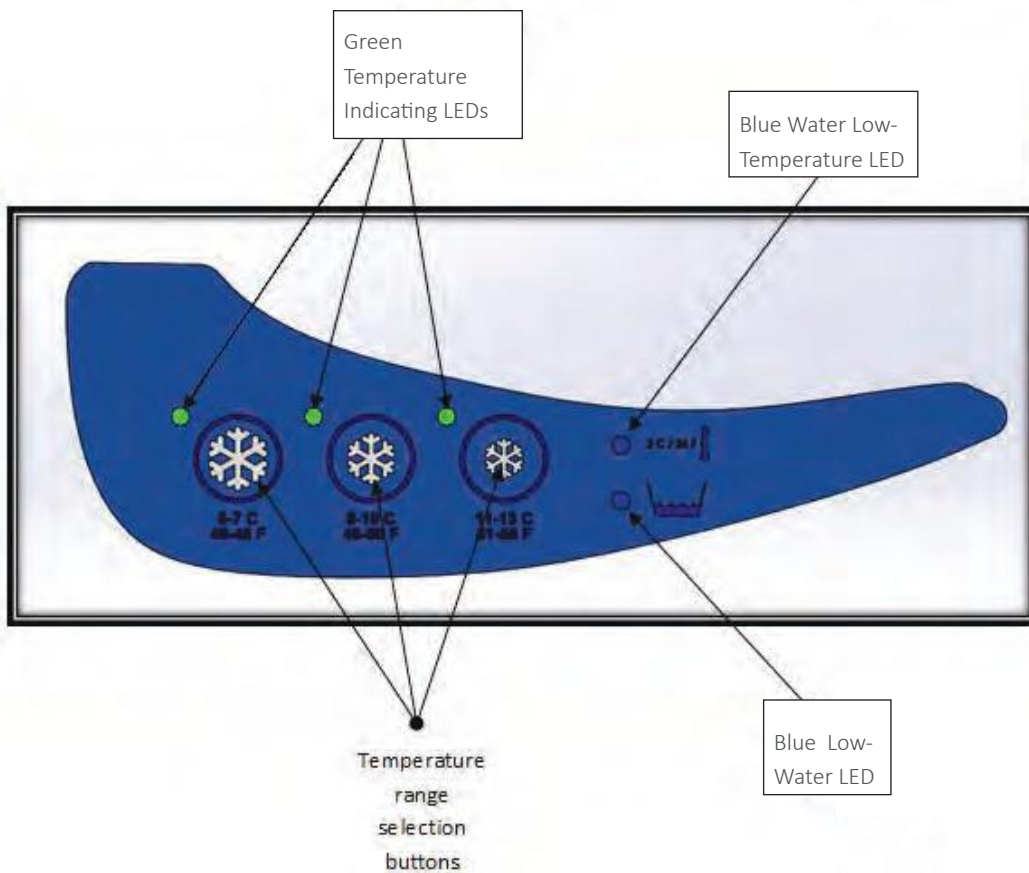

Figure 3 - Electri-Cool II Membrane Control Panel

Operation & Service Manual

11.6 Accessories

Thermal Pads consist of two layers of plastic sealed together to provide multiple passageways for water flow in a random-flow pattern designed to prevent occlusion.

The essential accessories for the Electri-Cool® II are listed below:

| Localized Cold Therapy Pads | |
|------------------------------------|--------------------|
| Description | Non-Sterile |
| 8" x 12" (20.3cm x 30.5cm) | 812-NS |
| 8" x 14" (20.3cm x 35.6cm) | 814-NS |
| 11" x 12" (27.9cm x 30.5cm) | 1112-NS |
| Universal (Knee / Shoulder) | CT-99-NS |

| Maxi-Therm® Lite Pads | |
|--------------------------------|------------------------|
| Description | Category Number |
| 12.5" x 18" (31.8cm x 45.7cm) | 873 |
| 25" x 19" (63.5cm x 31.8cm) | 872 |
| 22" x 17.25" (55.9cm x 43.8cm) | 871 |
| 25" x 4" (63.5cm x 10.2cm) | 870 |

| Other Accessories | |
|--|------------------------|
| Description | Category Number |
| 6' (1.83m) Connecting Hose, Insulated | 757-HIE |
| 12" (1 ft.)(30.5cm) Dual Pad Connecting Hose | 757-H1D |
| Bed Bracket | 767-BBK |
| Universal Stand (must purchase EC-080) | UNV LPS |
| Adapter Plate for Universal Stand | EC-080 |
| Dual-Matic (Temp Tester, Flow Meter) | TF-100 |

11.7 Pad Instructions

The Electri-Cool® II has been designed and tested to be used with GENTHERM thermal pads. Use of unapproved pads is not recommended. GENTHERM pads allow maximum flow while resisting restriction or kinks.

1. Read and understand operation manual before connecting pad to Electri-Cool® II.
2. Read and understand pad application instructions accompanying GENTHERM pad.
3. Connect hose to unit by inserting connectors on hose into connectors on unit. Connectors should “click” as they lock together.
4. Apply pad to patient and attach pad to hose by inserting connectors on pad into hose connectors. Normal use of the pad is to be applied in direct contact with the patient. Pad may be used over or under a patient, in the flat state or wrapped around patient.
5. Turn unit “ON” and set to temperature.
6. After pad has filled, check water level in unit. Add sterile water or water that has been passed through a filter less than or equal to 0.22 microns, only if necessary.
7. When therapy needs to be paused, disconnect the pad from the Electri-Cool II and allow the unit to continue to run.

NOTE: Reconnect the pad when ready to resume therapy.

8. When therapy is no longer needed disconnect pad from hose by pressing metal clips. Dispose of pad.
9. Turn unit “OFF” at the power switch and unplug the power cord from the outlet.

11.8 Disposal

Medical Devices that come in contact with patients present the risk of bio-contamination. This device generates no waste products or residues under normal use and normal cleaning routines. Follow local State and Hospital guidelines regarding disposal of medical devices at the end of their useful lives.

11.9 Cleaning (External)

The Electri-Cool® II case is constructed of plastic. For cleaning and disinfecting, always use conventional hospital-approved topical equipment cleaners and disinfectants that do not contain alcohol. Avoid alcohol and other strong, undiluted disinfectants. These may cause staining of the device’s outer skin. Thoroughly wipe down device with a damp cloth to remove any residue from cleaning solutions. For internal cleaning, please see procedure in section 37.0 on page 122.

Operation & Service Manual

11.10 Storage



CAUTION: Always drain the Electri-Cool® II to a sanitary drain because bio-contaminants may be present in the unit's water supply.

Drain the reservoir completely and clean thoroughly prior to storage of the Electri-Cool II. Contact the Gentherm Technical Service Department for the reservoir disinfection procedure.

12.0 Electromagnetic Emissions

Table 2. Presented in Fulfillment of IEC 60601-1-2

| Guidance and manufacturer's declaration – electromagnetic emissions | | |
|---|------------|--|
| The Electri-Cool II system is intended for use in the electromagnetic environment specified below. The customer or the user of the Electri-Cool II system should assure that it is used in such an environment. | | |
| Emissions tests | Compliance | Electromagnetic environment – guidance |
| RF emissions CISPR 11 | Group 1 | The Electri-Cool II system uses RF energy only for its internal function. Therefore, its RF emissions are very low and are not likely to cause any interference in nearby electronic equipment. |
| RF emissions CISPR 11 | Class A | The Electri-Cool II system is suitable for use in all establishments other than domestic and those directly connected to the public low-voltage power supply network that supplies buildings used for domestic purposes. |
| Harmonic emissions IEC 61000-3-2 | Class A | |
| Voltage fluctuations/ flicker emissions IEC 61000-3-3 | Complies | |

Table 3. Electromagnetic Immunity

| Guidance and manufacturer's declaration – electromagnetic immunity | | | |
|--|--|--|---|
| The Electri-Cool II system is intended for use in the electromagnetic environment specified below. The customer or the user of the Electri-Cool® II system should assure that it is used in such an environment. | | | |
| Immunity test | IEC 60601 test level | Compliance level | Electromagnetic environment - guidance |
| Electrostatic discharge (ESD) IEC 61000-4-2 | ±6 kV contact ±8 kV air | ±6 kV contact ±8 kV air | Floors should be wood, concrete or ceramic tile. If floors are covered with synthetic material, the relative humidity should be at least 30%. |
| Electrical fast transient/ burst IEC 61000-4-4 | ±2 kV for power supply lines ±1 kV for input/output lines | ±2 kV for power supply lines ±1 kV for input/output lines | Mains power quality should be that of a typical commercial or hospital environment. |
| Surge IEC 61000-4-5 | ±1 kV differential mode ±2 kV common mode | ±1 kV differential mode ±2 kV common mode | Mains power quality should be that of a typical commercial or hospital environment. |

Table 3. Electromagnetic Immunity

| Guidance and manufacturer's declaration – electromagnetic immunity | | | |
|---|--|--|---|
| <p>Voltage dips, short interruptions and voltage variations on power supply input lines</p> <p>IEC 61000-4-11</p> | <p><5% UT (>95% dip in UT) for 0,5 cycle</p> <p>40% UT (60% dip in UT) for 5 cycles</p> <p>70% UT (30% dip in UT) for 25 cycles</p> <p><5% UT (>95% dip in UT) for 5 s</p> | <p><5% UT (>95% dip in UT) for 0.5 cycle</p> <p>40% UT (60% dip in UT) for 5 cycles</p> <p>70% UT (30% dip in UT) for 25 cycles</p> <p><5% UT (>95% dip in UT) for 5 s</p> | <p>Mains power quality should be that of a typical commercial or hospital environment. If the user of the Electri-Cool® II system requires continued operation during power mains interruptions, it is recommended that the Electri-Cool® II system be powered from an uninterruptible power supply or a battery.</p> |
| <p>Power frequency (50/60 Hz) magnetic field</p> <p>IEC 61000-4-8</p> | <p>3 A/m</p> | <p>3 A/m</p> | <p>Power frequency magnetic fields should be at levels characteristic of a typical location in a typical commercial or hospital environment.</p> |
| <p>Note: UT is the a.c. mains voltage prior to application of the test level.</p> | | | |

Maintenance Section

Operation & Service Manual

13.0 Maintenance

13.1 Overview

Maintenance and service activities will sometimes overlap. In general, maintenance refers to any activity that does not require a certified technician. Maintenance may be performed by healthcare personnel or by other trained persons.

The following actions are considered maintenance:

- Exterior inspection, cleaning, and disinfection
- Replacing hoses
- Cleaning hoses, pads
- Draining reservoirs

Service refers to any activity that requires a Medical Equipment Service Technician, Certified Biomedical Electronics Technician, or a Certified Clinical Engineer. See section 17.0 on page 26. The following actions are considered service:

- Equipment or parts replacement
- Repairs
- Cleaning/disinfecting water reservoirs

13.2 Inspection Frequency

- Gentherm suggests performing maintenance procedures every quarter. Document the results on the “Preventive Maintenance Inspection Sheet” on page 33.

13.3 Exterior Physical Inspection & Cleaning

- Look for cracked, bent, missing, or otherwise damaged parts. Carefully inspect the power cord for cuts or exposed wire. Check the plug for missing or bent pins. Check the hoses and pads for leaks or kinks.
- See section 11.9 Cleaning (External), on page 1313.

13.4 Draining the Reservoir

- See section 37.1 Draining the Electri-Cool II, on page 122.



Filter

14.0 Air Filter Inspection and Replacement

Inspect filter before each use of unit. Remove air filter retainer to access the air filter on the bottom of the unit. Inspect the filter for accumulated dust. If the filter is 30% clogged with dust, replace filter with a new one and reattach the air filter retainer.

Tools:

- Slotted screwdriver

Parts provided:

- Filter



Tools

Operation & Service Manual

14.1 Remove the Filter Retainer

1. Unplug the unit from any power source.

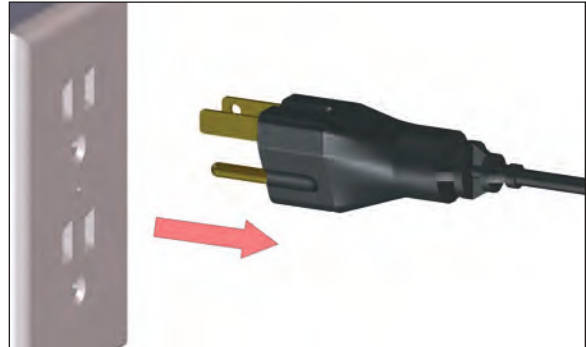

Figure 4 - Step 1 Unplug power cord

2. Use a slotted screwdriver to pry where the filter retainer meets with the filter housing. Take care to not damage the fan guard beneath.



Figure 5 - Step 2 Pry off retainer

3. Discard the used filter.



Figure 6 - Step 3 Discard used filter

Maintenance

Electri-Cool II Model 767

4. Place a new filter in the filter retainer recess.

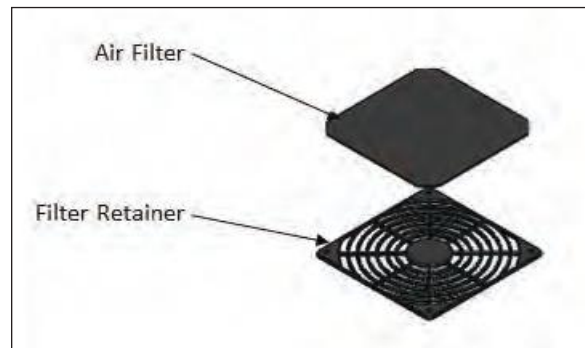

Figure 7 - Step 4 Place filter in retainer

5. Align the four tabs to the slots of the filter housing.

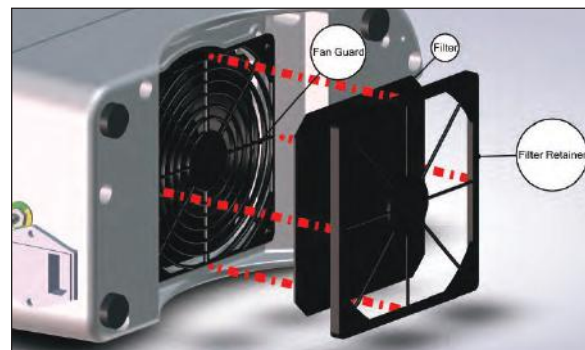

Figure 8 - Step 5 Align tabs to slots

6. Press firmly until the retainer snaps into place.

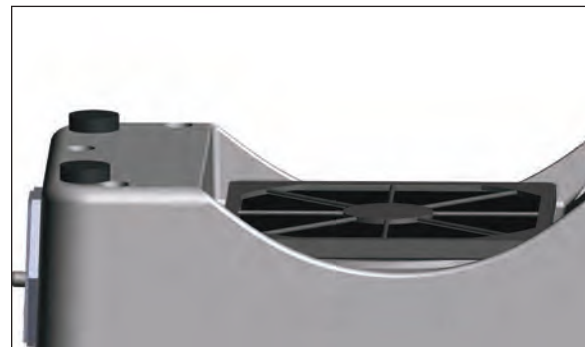

Figure 9 - Step 6 Press retainer into place

15.0 Draining the Reservoir

The Electri-Cool II must be drained at least every 30 days. The unit must also be drained prior to storage, and prior to transportation.

1. Unplug the unit from any power source.
2. Place the unit over a sanitary drain.

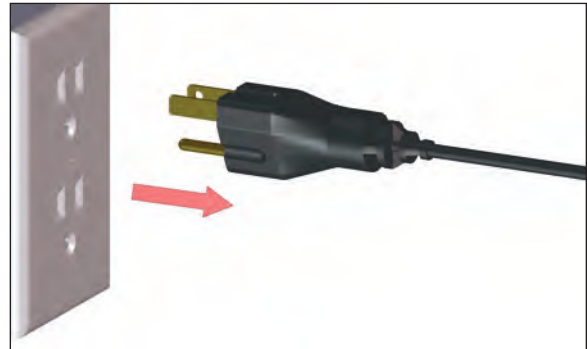

Figure 10 - Step 1 Unplug power from mains

3. Open the reservoir lid.



Figure 11 - Step 3 Open reservoir lid

4. Tip the unit forward to drain the water from the reservoir.



Figure 12 - Step 4 Tip unit forward

Service Section

16.0 Troubleshooting Guide

16.1 General

This section provides information to aid the service technician in diagnosing problems with the Electri-Cool® II system. The left column lists problems which may occur; the right column lists the most probable causes of the problem.

Table 4. Troubleshooting

| Problem | Probable Cause |
|------------------------------------|---|
| Unit will not turn on | Unit not plugged into proper voltage supply |
| | Blown fuse |
| | Loose connector |
| Unit turns on, but will not pump | Kinks in pad/hose |
| | Improper connections to pad/hose |
| | Improper connections to PC board |
| | Defective PC board |
| Unit will not cool | Air filter clogged |
| | Air intake blocked |
| | Air outlet vents restricted |
| Low water warning light/audible on | Reservoir water level too low |
| | Unit tilted |
| | Defective PC board(s) |
| Low temp warning light/audible on | Water used to fill pump too cold |
| | No water flow |
| | Defective PC board(s) |
| LEDs will not illuminate | Defective membrane control panel |
| | Defective PC board |
| Desired setting cannot be set | Defective membrane control panel |
| | Defective PC board |

Table 4. Troubleshooting

| Problem | Probable Cause |
|--|--|
| Ground continuity exceeds 0.2 Ohms. | Loose or disconnected ground (green) wire(s) |
| | Defective connector on ground wire |
| | Defective power cord |
| Leakage current exceeds 300 microamperes | Defective power supply |

16.2 Indicator Specifics

| Indicator Condition | Indicator |
|-----------------------------------|---------------------------------------|
| Water Low Temp Limit | Constant blue LED & audible indicator |
| Low Water | Constant blue LED & audible indicator |
| Internal Heatsink High Temp Limit | Unit completely shuts down |

17.0 Service

Maintenance and service activities will sometimes overlap. In general, maintenance refers to any activity that does not require a certified technician. Maintenance may be performed by healthcare personnel or by other trained persons.

The following actions are considered maintenance:

- Inspecting, cleaning, and disinfecting the exterior
- Replacing hoses
- Cleaning hoses, pads
- Draining reservoirs

Service refers to any activity that requires a Medical Equipment Service Technician, Certified Biomedical Electronics Technician, or a Certified Clinical Engineer. The following actions are considered service:

- Equipment or parts replacement
- Repairs
- Cleaning/disinfecting water reservoirs
- Replacing hoses, cords, and other accessories



WARNING: Always unplug the unit before accessing internal components during service. Failure to unplug the unit could result in electric shock.



WARNING: ALL ground wires must be connected. Improper grounding may result in electric shock.



WARNING: Working with electronic boards, plugs, and cables requires delicate handling. Proper Electrostatic Discharge (ESD) procedures should be followed during replacement of any electronic board. Failure to do so may result in damage to the board.

18.0 ECII Interior Access



WARNING: ALL ground wires must be connected. Improper grounding may result in electric shock.



CAUTION: Working with electronic boards, plugs, and cables requires delicate handling. Proper Electrostatic Discharge (ESD) procedures should be followed during replacement of any electronic board. Failure to do so may result in damage to the board.

NOTE: Drain the reservoir before removing any part from the unit.

All internal operating components are accessible by separating the front and rear enclosure. Refer to Figure 16 to see the parts locations and general construction. Place the Electri-Cool unit on a stable work surface before beginning any service.

Operation & Service Manual

18.1 Flow Test

Maximum flow rate is obtained with the water temperature at room temperature and the pad lying flat on a smooth surface.

1. Plug the device into a power source and turn it on. If no flow rate is observed, check the pad and hose for kinks, or reversed connections to the pump.
2. Allow water temperature to reach room temperature and check flow rate with a flow meter. If the flow rate is substantially less than 68 LPH (18 GPH), check the pump for restrictions. Visually check the hose and pad to see water flow thru the pad. To check the actual flow rate use the Dualmatic only.

18.2 Water Leak Test

Tools needed: none.

Parts provided: none.

Parts needed: Bypass hose with male quick disconnects. Sold separately.

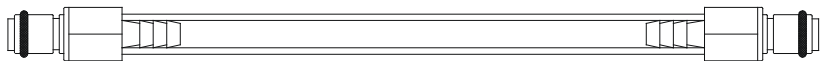

Quick disconnects will fit 1/4 in. ID hose (x2)

Hose is 1/4 in. ID (x1)

1. When removing covers to check for internal water leaks, the assembly person or service technician must be grounded with an ESD mat and wristband or equivalent.
2. Fill reservoir with sterile water or water that has been passed through a filter less than or equal to 0.22 microns.
3. Connect bypass hose to both quick-disconnect connectors.
4. Turn unit on.
5. Check Electri-Cool II for any water leaks.

18.3 Temperature Test

Tools needed:

- In-line temperature probe
- Six-foot insulated connecting hose
- Timer
- Pad

1. Remove the device from any power source.
2. When removing covers to check for internal water leaks, the service technician must be grounded with an ESD mat and wristband or equivalent.
3. Attach an in-line temperature probe to the device's outlet and a six foot insulated connecting hose with a pad to the return port of the machine.
4. Plug the device into a power source, turn the unit on, and set the temperature to 5°C - 7°C (40°F - 45°F). When the temperature probe reads between 3.9°C – 8.1°C (31°F - 47°F), start the timer. After at least five (5) minutes, record the temperature probe reading. The reading must be within 3.9°C – 8.1°C (31°F - 47°F).
5. Set the temperature on the device to 8°C - 10°C (46°F - 50°F). When the temperature probe reads between 6.9°C – 11.1°C (44°F - 52°F), start the timer. After at least five (5) minutes record the temperature probe reading. The reading must be within 6.9°C – 11.1°C (44°F - 52°F).
6. Set the temperature on the device to 11°C - 13°C (51°F - 55°F). When the temperature probe reads between 9.9°C – 14.1°C (50°F - 57°F), start the timer. After at least five (5) minutes record the temperature probe reading. The reading must be within 9.9°C – 14.1°C (50°F - 57°F).
7. Turn the device OFF.

18.4 Low Water Switch/Indicator Test

To perform this test:

1. Unit must be plugged into a power source and running.
2. Open the reservoir access lid.
3. Reach into the reservoir to the float switch and push the float all the way down to its lowest possible position. The low water indicator should sound and the low water level LED on the membrane control panel should light. The unit will stop pumping water and stop cooling immediately.
4. Release the float and let it rise to its highest position. The unit should now resume normal operation, and the alarms should stop.

Operation & Service Manual

18.5 Leakage Current Test

1. Unit must be plugged into a power source and running.
2. Connect the leakage current tester ground lead clamp to the equipotential ground on the back of the unit.
3. Test unit in all combinations of power switch off and on, normal and reverse polarity, and normal and open ground. Record the highest reading. If the readings indicate more than 300 microamperes (for 100V/115V) or more than 500 microamperes (for 230V/240V), refer to the Service Checklist 19.0 Preventive Maintenance for Service Personnel, on page 33.

18.6 Ground Continuity Test

Using an ohmmeter, measure the resistance between the ground lug and the ground pin of the power plug. This value shall not exceed 0.2 ohm. If higher than 0.2 ohm, see section 19.0 Preventive Maintenance for Service Personnel, on page 33.

18.7 Water Temperature Low-Limit Thermistor Test



WARNING: Electric shock hazard may be present.

Control Board P/N: 39990

This test is for devices with a control board labeled “P/N: 39990. This includes most devices with serial number 043-76700185 and later. The last 5 digits are sequential.

1. Unplug the unit from any power source.
2. Disconnect any hoses or pads from the device.
3. Follow instructions for section 20.1 Rear Enclosure and Reservoir Lid Removal, on page 39.
4. Move the jumper at J9 on the control board from the OPERATE to the TEST position.
5. Plug in the unit and turn it on. Wait for it to go through self-calibration, approximately 5 seconds.
6. Locate the 8-position Molex plug (J4) on the control board. When the indicator sounds, turn the device OFF, remove the 8-position Molex plug (J4) and quickly measure the resistance at the control thermistor (white wires).
7. Determine the equivalent temperature using Appendix A on page 124. Record the equivalent temperature of the control thermistor in Table 5 of section 19.0 Preventive Maintenance for Service Personnel, on page 33.
The equivalent temperature must be $2.2^{\circ}\text{C} \pm 1.1^{\circ}\text{C}$.

8. Confirm that the indicator sounds and verify the low temperature LED lights up.
9. Move the jumper at J9 on the control board from the TEST to the OPERATE position and reconnect the 8-position connector from the TE subassembly to the control board.
10. Record N/A for the low temp thermistor in Table 5. Preventive Maintenance Inspection Sheet, on page 33.
11. Follow instructions for section 20.2 Rear Enclosure and Reservoir Lid Installation, on page 41.

18.8 Internal Physical Inspection

1. Follow instructions for 20.1 Rear Enclosure and Reservoir Lid Removal, on page 39. Carefully inspect the unit for any signs of leaks, loose components, or damage. Check wiring for breaks in insulation, exposed wires, loose connections, etc. Repair or replace components as necessary and retest unit before placing back into service.
2. Once inspection is complete, follow instructions for section 20.2 Rear Enclosure and Reservoir Lid Installation, on page 41.

Operation & Service Manual

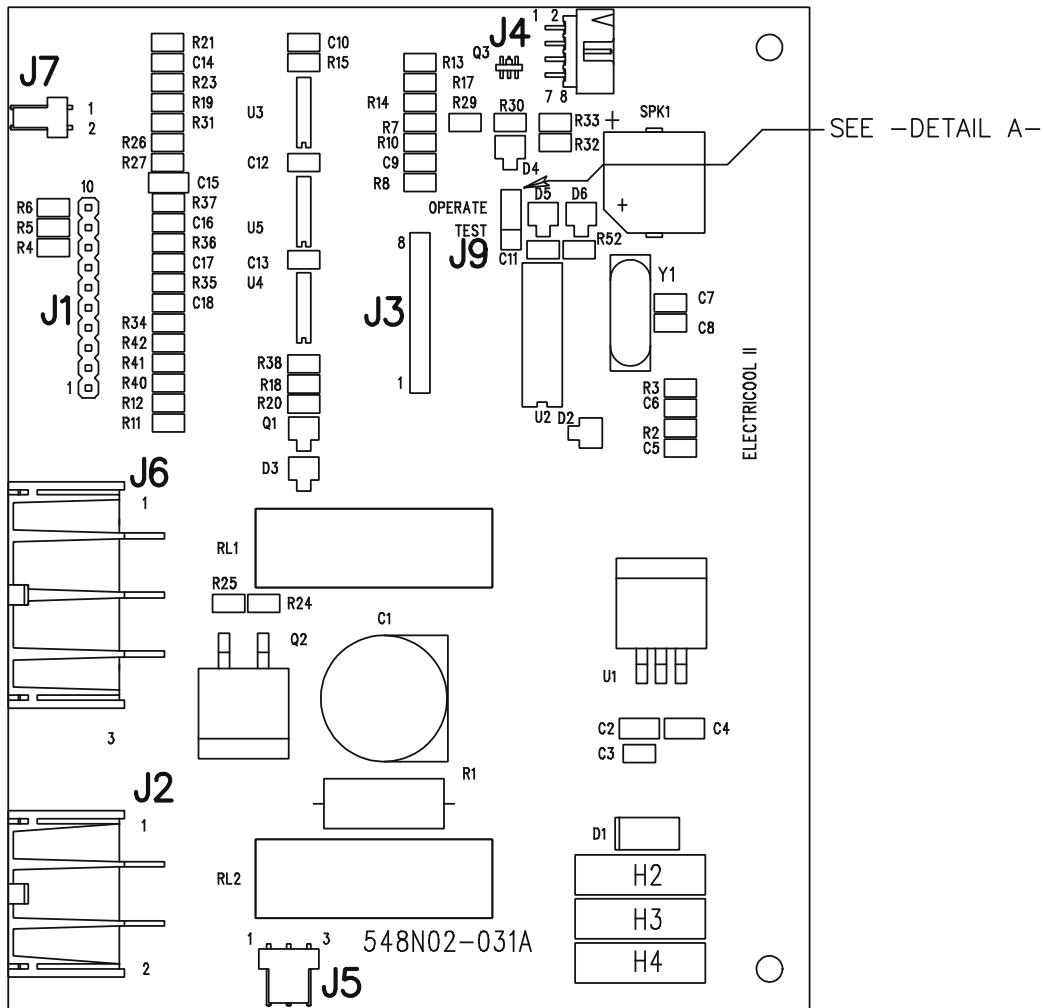

Figure 13 - Control board diagram

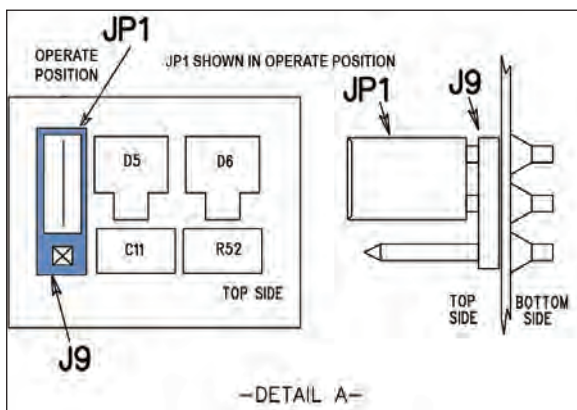

Figure 14 - Detail A Operate Position

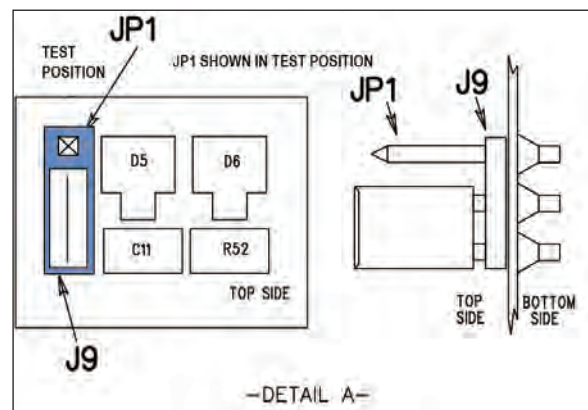

Figure 15 - Detail A Test Position

19.0 Preventive Maintenance for Service Personnel

Table 5. Preventive Maintenance Inspection Sheet

| Daily Preventive Maintenance Inspection Sheet | | | | |
|---|--|--|--------------|------------------|
| | | | | |
| | Date | | | |
| Section | Procedures | | | |
| 13.3 | Exterior Physical Inspection | | Value | Pass/Fail |
| | External enclosure in good condition, No cracks, bent, missing, or damaged parts | | | |
| | Control panel is free of damage and legible | | | |
| | All labels legible and secure | | | |
| | Power cord and strain relief is free of cuts, damage or exposed wire | | | |
| | Power plug has no bent or missing ground prongs | | | |
| | Quick disconnect couplings are tight, straight, and not leaking. | | | |
| | Rubber feet are free of damage and secure | | | |
| 14.0 | Air Filter Inspection | | Value | Pass/Fail |
| | Air filter is not 30% or more clogged with dust | | | |
| | Air filter is free of cuts, tears, or holes | | | |
| | Air filter extends across all filter retainer openings when installed | | | |
| 11.4 | Functional Verification | | Value | Pass/Fail |
| | Startup sequence completes properly | | | |
| | Check audible and visual indicators | | | |
| | Check water flow through the pad (check water level and refill if needed) | | | |

Operation & Service Manual

| Monthly Preventive Maintenance Checklist | | | |
|--|---|--------------|------------------|
| 18.1 | Flow Test | Value | Pass/Fail |
| | Check flow rate is minimum 68 LPH (18 GPH) | | |
| 18.7 | Water Temperature Low-Limit Thermistor Test | Value | Pass/Fail |
| | Temperature reading when set at 5-7 °C (40-45 °F). | | |
| | Reading within 3.9-8.1 °C (31-47 °F) | | |
| | Temperature reading when set at 8-10 °C (46-50 °F) | | |
| | Reading within 6.9-11.1 °C (44-52 °F) | | |
| | Temperature reading when set to 11-13 °C (51-55 °F) | | |
| | Reading within 9.9-14.1 °C (50-57 °F) | | |
| | Low Water Switch / Indicator Test | | |
| 18.5 | Leakage Current Test | Value | Pass/Fail |
| | Power switch off, reverse polarity, ground disconnected | | |
| | Power switch off, reverse polarity, ground connected | | |
| | Power switch off, normal polarity, ground disconnected | | |
| | Power switch off, normal polarity, ground connected | | |
| | Power switch on, reverse polarity, ground disconnected | | |
| | Power switch on, reverse polarity, ground connected | | |
| | Power switch on, normal polarity, ground disconnected | | |
| | Power switch on, normal polarity, ground connected | | |

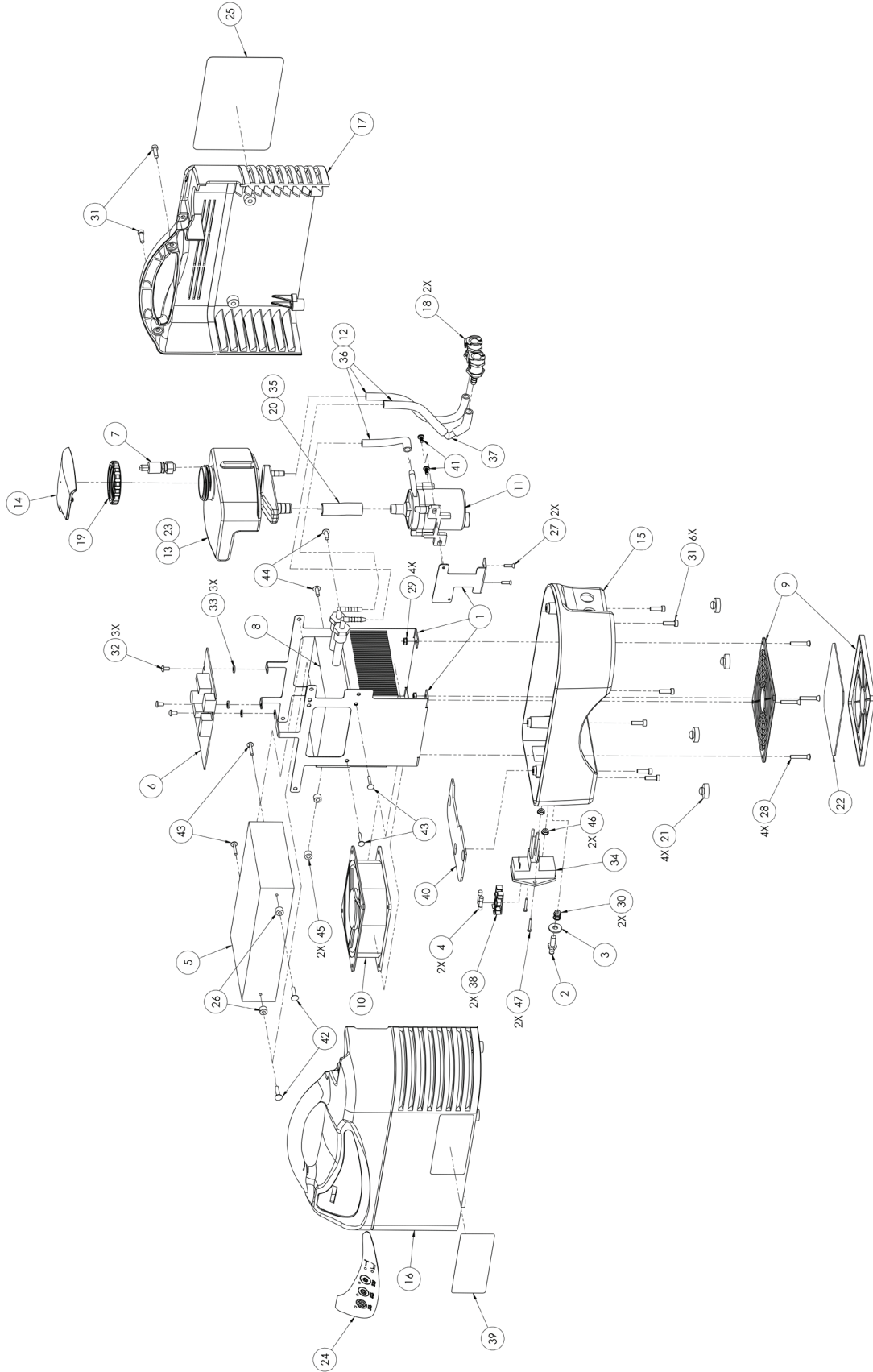

Figure 16 - Exploded view with callouts

Operation & Service Manual

Table 6. Parts List

| Item # | Name | Qty. |
|--------|---|------|
| 1 | Brackets | 3 |
| 2 | Lug Ground, Euro | 1 |
| 3 | Ground Lug Washer, Green/Yellow | 1 |
| 4 | Fuse | 2 |
| 5 | Power Supply | 1 |
| 6 | Control Board | 1 |
| 7 | Float Switch | 1 |
| 8 | TE Module | 1 |
| 9 | Fan Guard | 1 |
| 10 | Fan Motor | 1 |
| 11 | Pump | 1 |
| 12 | Insulation Tubing, 3/8" ID x 1/8 W | 1 |
| 13 | Reservoir | 1 |
| 14 | Reservoir Lid | 1 |
| 15 | Bottom Enclosure | 1 |
| 16 | Front Enclosure | 1 |
| 17 | Back Enclosure | 1 |
| 18 | Panel Mount Coupling | 2 |
| 19 | Reservoir Collar | 1 |
| 20 | PVC Tubing, 12 mm ID x 16 mm OD | 1 |
| 21 | Rubber Feet | 4 |
| 22 | Air Filter | 1 |
| 23 | Reservoir Insulation | 1 |
| 24 | Membrane Control Panel | 1 |
| 25 | Exterior Spec Label | 1 |
| 26 | Plastic Spacer, #8 x 3/8 | 2 |
| 27 | Flat Head SS M/S, #8-32 x 1/2" | 2 |
| 28 | Phillips Oval Head SS M/S, #8-32 x 1" | 4 |
| 29 | Keps nut, #8-32 Zinc | 4 |
| 30 | Keps nut, Plated M6 | 2 |
| 31 | Filister Head Screw, #10-24 x 3/4" | 8 |
| 32 | Plastic Pan Head Phillips Screw, #8-32 x 1/4" | 3 |
| 33 | Plastic Washer, #8 | 3 |
| 34 | Wire Harness Assembly | 1 |

Service

Electri-Cool II Model 767

| Item # | Name | Qty. |
|------------------|--|------|
| 35 | Insulation Tubing, 1/2" | 1 |
| 36 | Clear PVC Tubing, 1/4" ID x 3/8" OD | 1 |
| 37 | Barbed Elbow, 25 x 25 | 1 |
| 38 | Fuse Holder | 2 |
| 39 | Exterior Logo Label | 1 |
| 40 | Power Entry Shroud | 1 |
| 41 | Phillips Screw, #8-32 x 5/16" | 2 |
| 42 | Phillips Truss Head Screw, #8-32 x 3/4 | 2 |
| 43 | Head Screw, #8-32 x 3/8" | 4 |
| 44 | Phillips Screw, #8-32 x 1/2" | 2 |
| 45 | Nylon Spacer, Black | 2 |
| 46 | Keps nut, #4-40 SS | 2 |
| 47 | Phillips Pan Head SS M/S, #4-40 x 3/4" | 2 |
| Not Shown | | |
| 1 | Power Cord, 2.5 meters, 115V | 1 |
| 2 | 18" Velcro Strap | 1 |
| 3 | Carton | 1 |
| 4 | Operation Manual | 1 |
| 5 | #8 internal tooth L/W 410 SS | 1 |
| 6 | 6-foot Insulated hose | 1 |
| 7 | EMI Suppressor Core .680 | 1 |
| 8 | EMI Suppressor Core .993 | 1 |



20.0 Rear Enclosure and Reservoir Lid Replacement



CAUTION: Working with electronic boards, plugs, and cables requires delicate handling. Proper Electrostatic Discharge (ESD)

procedures should be followed during replacement of any electronic board. Failure to do so may result in damage to the board.

Note: If the rear enclosure replacement must be replaced for any reason, the specifications label on the back must also be replaced.

Tools Required: #2 Phillips screwdriver

Parts provided:

- Rear enclosure
- Reservoir lid



Tools and parts

20.1 Rear Enclosure and Reservoir Lid Removal

1. Disconnect the device from mains power (Figure 17).
2. Drain the device. See section 15.0 Draining the Reservoir, on page 22.

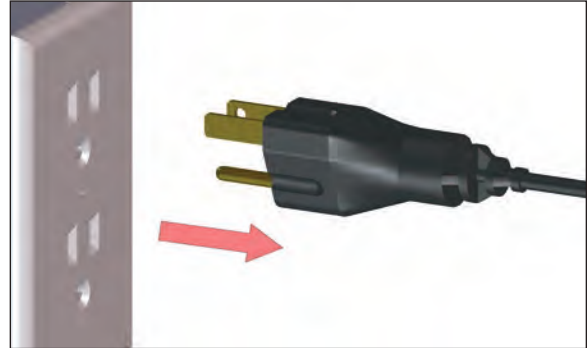

Figure 17 - Step 1 Unplug power cord

3. Remove the two handle screws. Do not discard the screws (Figure 18).

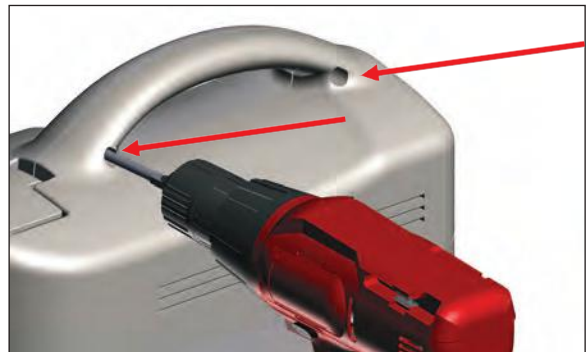

Figure 18 - Step 3 Remove two handle screws

4. Remove the two screws in the base that hold the base and rear enclosures together. Do not discard the screws (Figure 19).

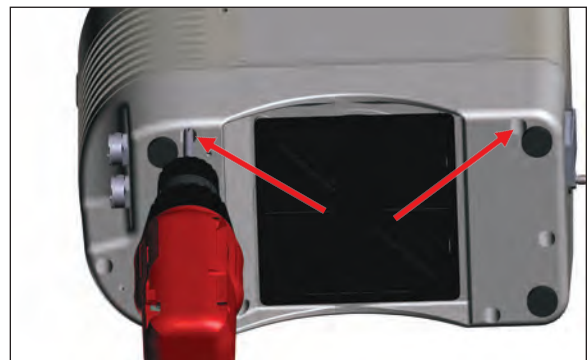

Figure 19 - Step 4 Remove two base screws

Operation & Service Manual

5. Remove the reservoir collar (Figure 20).

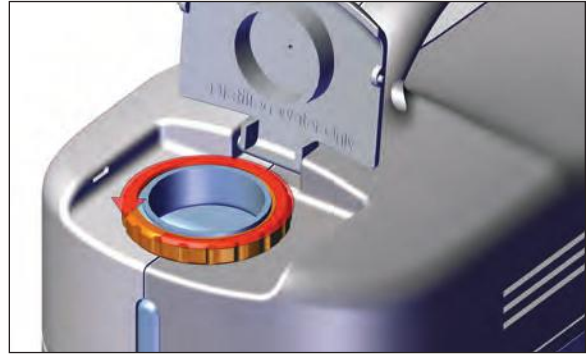

Figure 20 - Step 5 Remove collar

6. Lift rear enclosure with lid up and away (Figure 21).

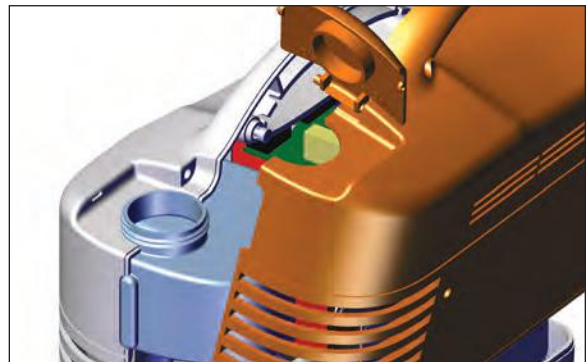

Figure 21 - Step 6 Lift rear enclosure with lid up and away

20.2 Rear Enclosure and Reservoir Lid Installation

1. Install enclosure and lid (Figure 22).

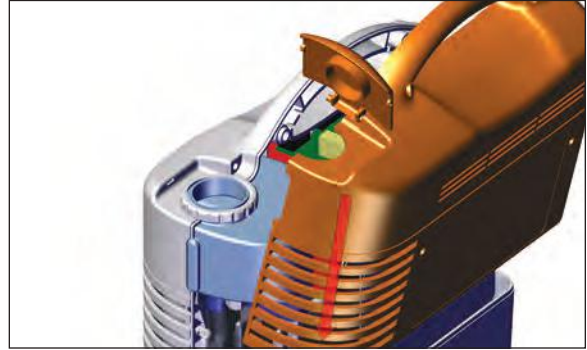

Figure 22 - Step 1 Install enclosure and lid

2. Screw on the reservoir collar (Figure 23).



Figure 23 - Step 2 Install reservoir collar

3. Secure the rear enclosure to the bottom enclosure using two #10-24 x 3/4" Phillips, fillister head screws (Figure 24).

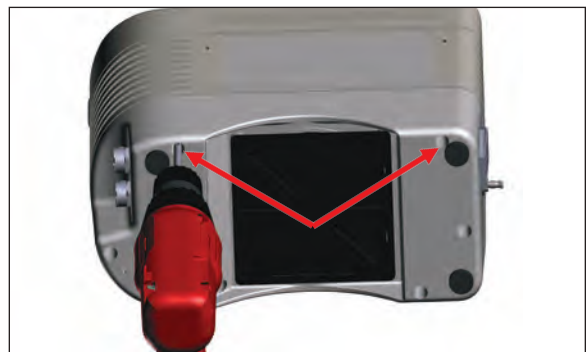

Figure 24 - Step 3 Install two base enclosure screws.

Operation & Service Manual

4. Secure the rear enclosure handle to the front enclosure handle with two #10-24 x 3/4" phillips, fillister-head screws (Figure 25).
5. Tighten all screws to 10 in-lbs.



Figure 25 - Step 4 Install two handle screws



21.0 Front Enclosure Replacement



CAUTION: Working with electronic boards, plugs, and cables requires delicate handling. Proper Electrostatic Discharge (ESD)

procedures should be followed during replacement of any electronic board. Failure to do so may result in damage to the board.

Note: If the front enclosure must be replaced for any reason, the logo label and the membrane panel must also be replaced (Step #2).

Tools:

- #2 Phillips screwdriver

Parts Provided:

- Front enclosure
- Logo label
- Membrane control panel with ribbon cable.



Tools

Operation & Service Manual

21.1 Front Enclosure Removal

1. Follow instructions for section 20.0 Rear Enclosure and Reservoir Lid Replacement, on page 38.
2. Place the unit on its back. Remove the four screws in the base (Figure 26). Do not discard the screws.

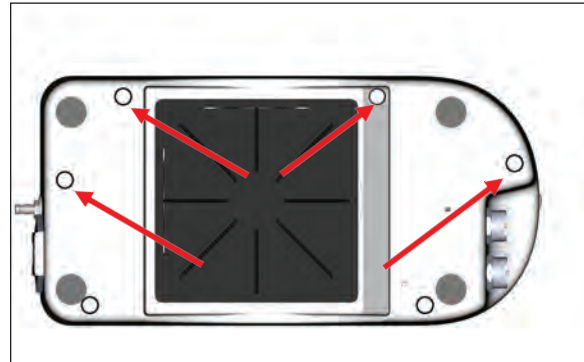

Figure 26 - Step 2 Remove four screws

3. Lift the front enclosure up and away from the base. **Note:** Be careful to not apply tension to the membrane ribbon cable.

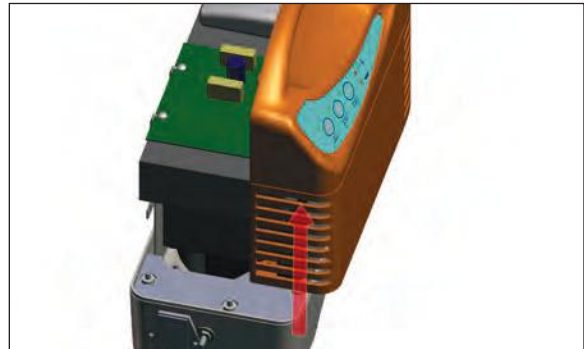

Figure 27 - Step 4 Remove front enclosure

4. Disconnect the membrane ribbon cable from the control board (Figure 28).

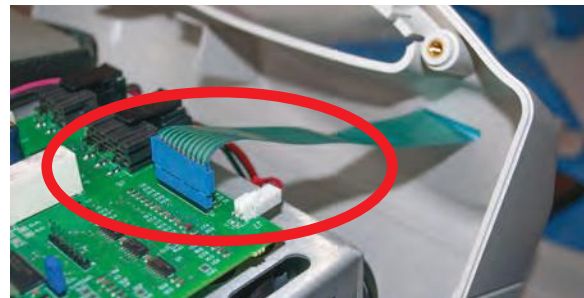

Figure 28 - Step 5 Disconnect ribbon cable

21.2 Front Enclosure Installation

1. Follow instructions for section 24.0 Membrane Panel Replacement, on page 53.
2. Install a new exterior logo label if required. Remove the adhesive backing from a corner of the label. Align it with the recessed area on the front enclosure and press the corner in place. Remove the remaining adhesive backer and roll the rest of the label in place.
3. Place the front enclosure into the bottom enclosure. Check to make sure that all wires are properly located within the enclosure (Figure 29). Ensure wires do not fall between the plastic divider and the reservoir.

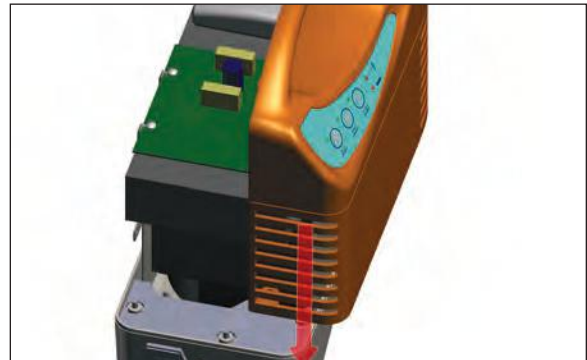

Figure 29 - Step 3 Install front enclosure.

4. Reconnect the membrane ribbon cable to connector J1 on the control board (Figure 30).

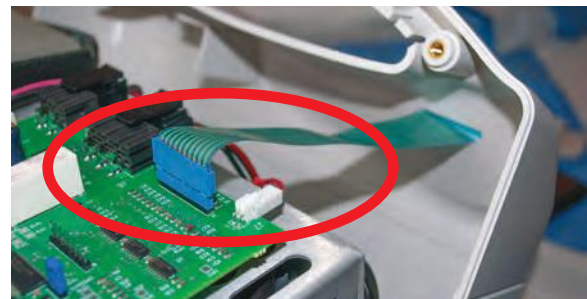

Figure 30 - Step 5 Reconnect ribbon cable

Operation & Service Manual

5. Install the front enclosure to the base enclosure with four #10-24 x 3/4" Phillips fillister head screws (Figure 31).
6. Perform the maintenance as defined in the "Preventive Maintenance for Service Personnel" on page 33.
7. Follow instructions for section 20.2 Rear Enclosure and Reservoir Lid Installation, on page 41.

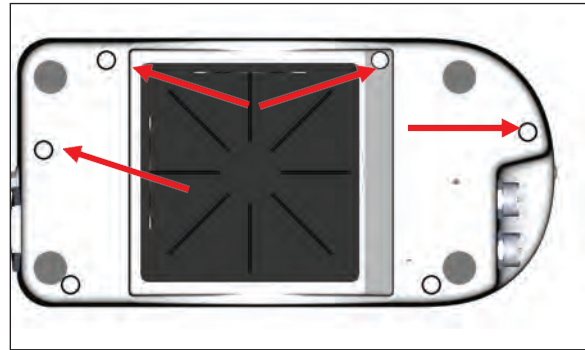

Figure 31 - Step 5 Install front enclosure



22.0 Bottom Enclosure Replacement



CAUTION: Working with electronic boards, plugs, and cables requires delicate handling. Proper Electrostatic Discharge (ESD)

procedures should be followed during replacement of any electronic board. Failure to do so may result in damage to the board.

NOTE: Do not bend any of the terminals

Tools:

- #2 Phillips screwdriver
- 11/32" wrench or socket
- (2) 10 mm open end wrenches

Parts Provided:

- Bottom enclosure



Tools

Operation & Service Manual

22.1 Bottom Enclosure Removal

1. Follow the instructions for section 20.0 Rear Enclosure and Reservoir Lid Replacement, on page 38.
2. Follow instructions for section 21.0 Front Enclosure Replacement, on page 43.
3. Follow the instructions for section 35.1 Fan Guard Removal, on page 107.
4. Follow the instructions for section 30.1 Power Inlet Removal, on page 81.
5. Remove the rubber feet and set them aside.
6. Follow the instructions for section 28.1 Quick Disconnect Removal, on page 72.

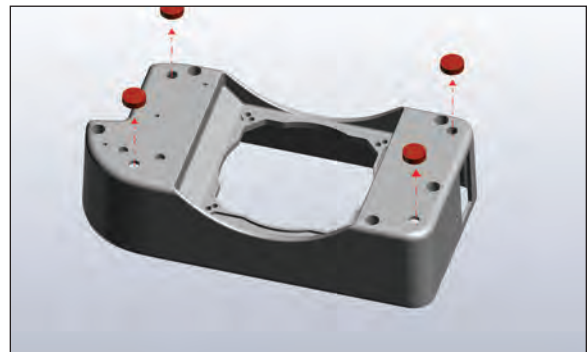

Figure 32 - Step 5 Remove rubber feet

22.2 Bottom Enclosure Installation

1. Install the feet by pushing them into place and pull and turn them from the inside to lock them in place.

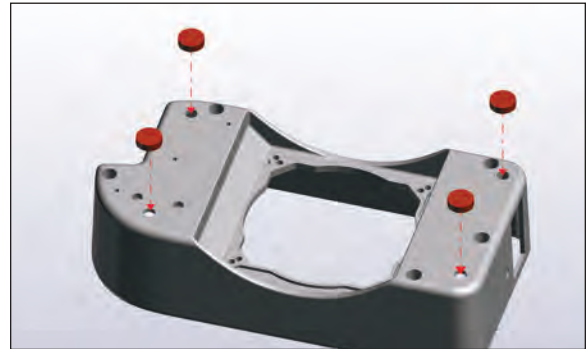

Figure 33 - Step 1 Install feet

2. Install BF applied part label next to the quick disconnect couplings (Figure 34).



Figure 34 - Step 2 Apply the BF label

3. Adhere GTIN label (Figure 35).
4. Follow instructions for section 28.2 Quick Disconnect Installation, on page 74.
5. Follow instructions for section 35.2 Fan Guard Installation, on page 110.
6. Follow instructions for section 30.2 Power inlet Installation, on page 84.
7. Follow instructions for section 23.2 Grounding Stud Installation, on page 51.



Figure 35 - Step 3 Apply the GTIN label

23.0 Equipotential Grounding Stud Replacement

Tools:

- 10mm open end wrench (2)

Parts provided:

- Stud replacement kit

23.1 Grounding Stud Removal

1. Use a 10mm open end wrench to remove the first Keps nut that holds the ground stud in place. Set the nuts aside.

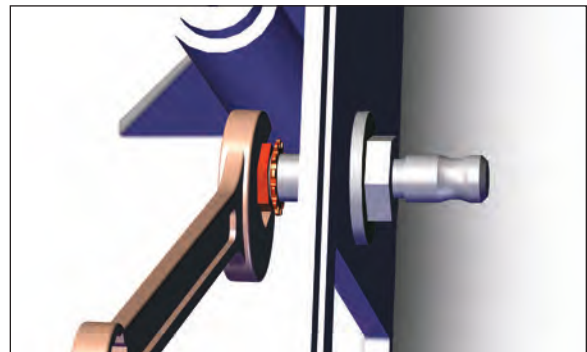

Figure 36 - Step 1 Remove 1st Keps nut

2. Remove the grounding wires and then remove the second Keps nut.
3. Remove the ground stud. Set it and the gold/white ring aside for reuse.

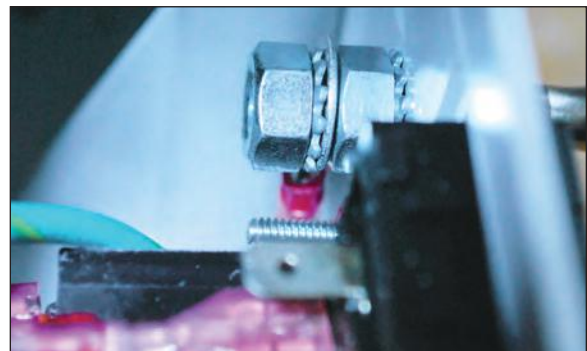

Figure 37 - Step 2 Remove ground wire and second Keps nut

23.2 Grounding Stud Installation

1. Insert the stud in the hole in the side of the bottom enclosure.



Figure 38 - Step 1 Insert stud

2. Slide the green and white ring over it so that the colors show to the outside of the enclosure.



Figure 39 - Step 2 Add the green and gold ring

Operation & Service Manual

3. Install Keps nut #1 on the outside of the base enclosure, and #2 Keps nut on the inside. Tighten both nuts with two open end wrenches.

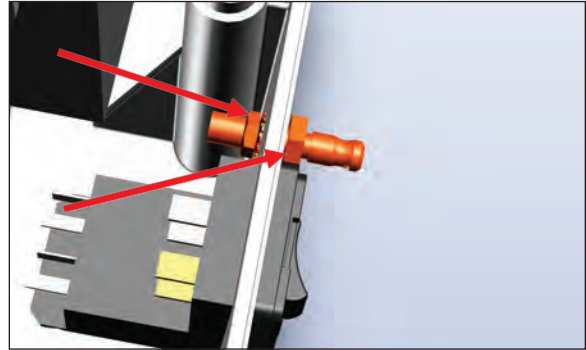

Figure 40 - Step 3 Install Keps nuts 1 & 2

4. Attach the ground wire and place Keps nut #3 on the end. Tighten Keps nut #3 with an open end wrench.

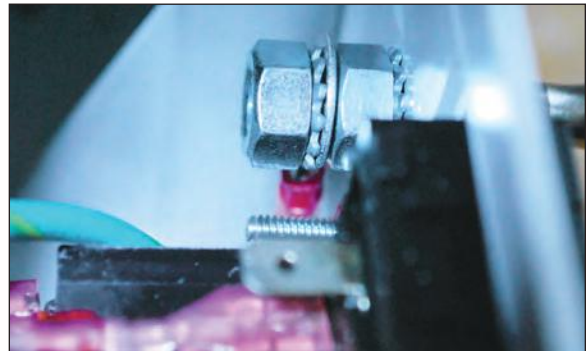
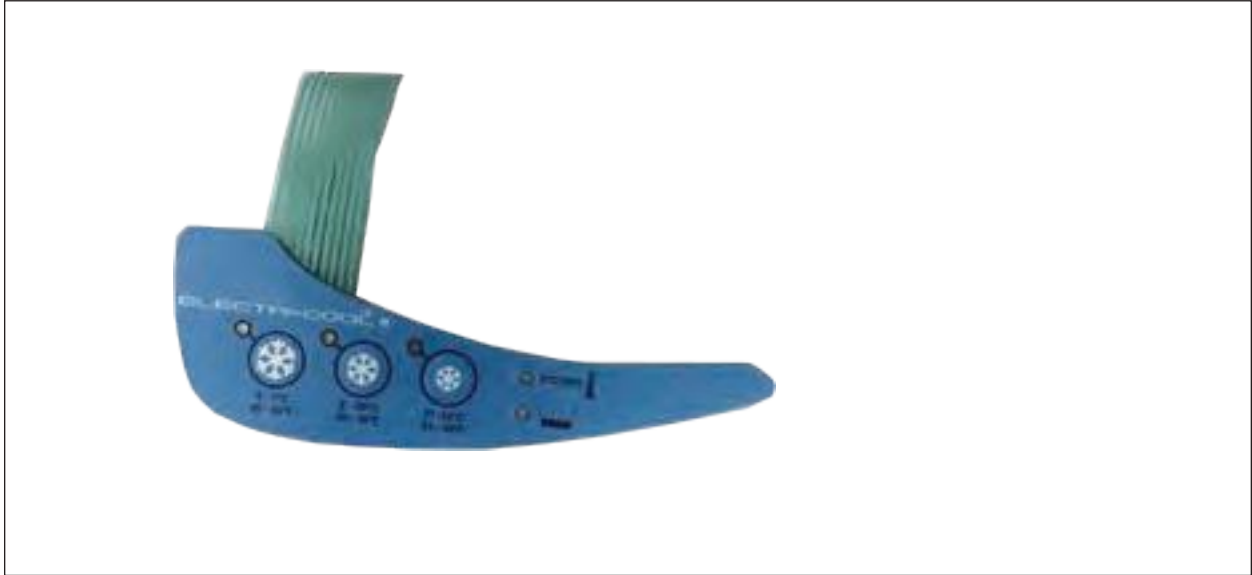

Figure 41 - Step 5 Attach ground wire and second Keps nut



Membrane Panel

24.0 Membrane Panel Replacement



CAUTION: Working with electronic boards, plugs, and cables requires delicate handling. Proper Electrostatic Discharge (ESD) procedures should be followed during replacement of any electronic board. Failure to do so may result in damage to the board.

Tools required:

- #2 Phillips screwdriver
- 3/16 inch flat screwdriver

Parts provided:

- Membrane panel



Tools

Operation & Service Manual

24.1 Membrane Panel Removal

1. Follow instructions for section 20.0 Rear Enclosure and Reservoir Lid Replacement, on page 38.
2. Follow instructions for section 21.0 Front Enclosure Replacement, on page 43.
3. Grasp the ribbon cable plug by the edges. Carefully unplug the ribbon cable from J1 on the circuit board (Figure 42).

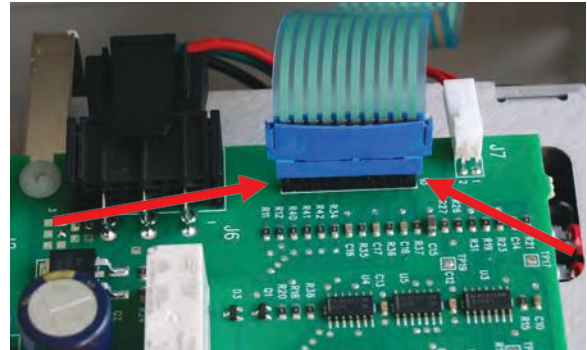

Figure 42 - Step 3 Unplug ribbon cable

4. Remove the old membrane panel by pushing a flat screw driver against the membrane through the ribbon cable slot from the inside of the front enclosure (Figure 43). Take care to avoid damaging the front enclosure surface when removing the membrane.



Figure 43 - Step 4 Push flat screwdriver through cable slot from the inside

24.2 Membrane Panel Installation

1. Thread the ribbon cable through the square cutout on the surface of the front enclosure (Figure 44).
2. Peel the adhesive backing off the new membrane panel.
3. Begin applying the membrane from the narrow end to the wide end. Align membrane with the edges of the recess and press membrane panel to the front enclosure.



Figure 44 - Step 1 Thread cable through slot

4. Attach the ribbon cable plug to J1 of the control board (Figure 45).
5. Follow instructions for section 21.0 Front Enclosure Replacement, on page 43.
6. Follow instructions for section 20.0 Rear Enclosure and Reservoir Lid Replacement, on page 38.
7. Perform the maintenance as defined in 19.0 Preventive Maintenance for Service Personnel, on page 33.

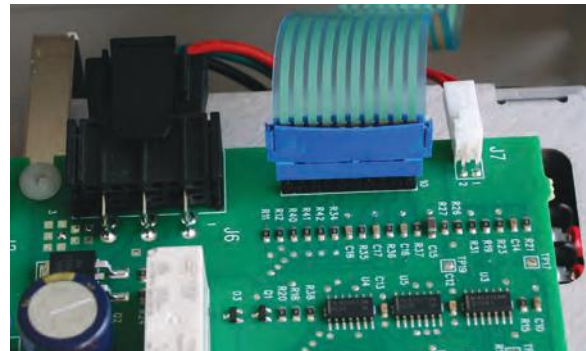
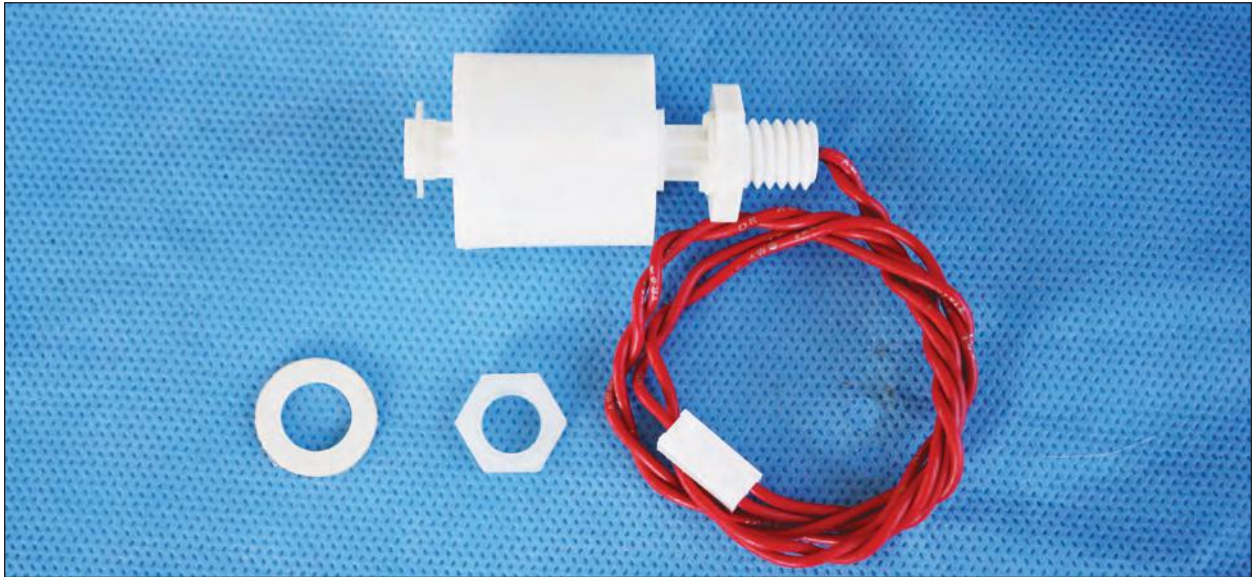

Figure 45 - Step 4 Connect ribbon cable



25.0 Float Switch Replacement

Tools required:

- 9/16" open end wrench

Parts provided:

- Float switch with gasket and mounting nut.

Float Switch

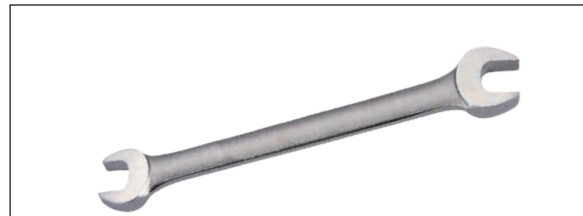

Tools

25.1 Float Switch Removal

1. Follow instructions for section 20.0 Rear Enclosure and Reservoir Lid Replacement, on page 38.
2. Follow instructions for section 21.0 Front Enclosure Replacement, on page 43.
3. Disconnect the float switch cable from J7 on the control board (Figure 46).



Figure 46 - Step 3 Disconnect J7

4. Loosen the reservoir insulation sufficiently enough to remove the float switch cable (Figure 47).

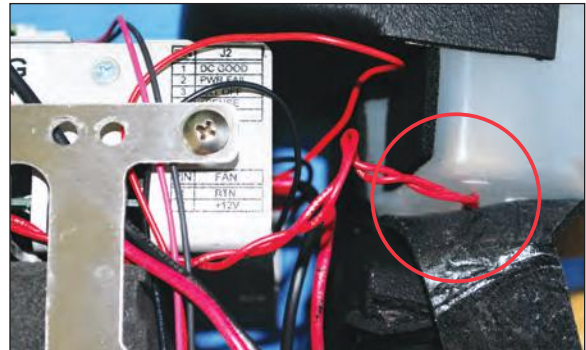

Figure 47 - Step 4 Loosen reservoir insulation

5. Unscrew the float switch mounting nut from the bottom of the reservoir (Figure 48).
6. Remove the float switch, the float switch wiring and gasket from the reservoir.



Figure 48 - Step 5 Unscrew float switch mounting nut

Operation & Service Manual

25.2 Float Switch Installation

1. Make sure the words “GEMS Sensors” on the float are facing up as the switch is installed. If the words will not face up, remove the float retainer clip and flip the float over. Then reinstall the float retainer clip.



Figure 49 - Step 1 GEMS orientation

2. Thread the float switch connector and wires through the accompanying gasket.



Figure 50 - Step 2 Thread wires through gasket

3. Insert the float switch connector and wires through the hole in the bottom of the reservoir.



Figure 51 - Thread connector and wires through reservoir

Service

Electri-Cool II Model 767

4. Secure the float switch in place beneath the reservoir with the accompanying nut (Figure 52).



Figure 52 - Step 4 Secure float switch mounting nut

5. Fasten the float switch cable under the reservoir insulation. Ensure the float switch wires extend towards the front left corner of the reservoir (Figure 53).

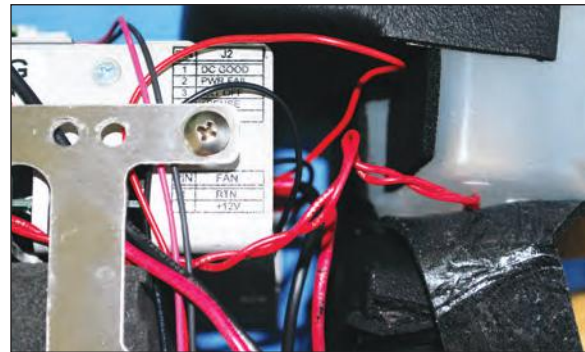

Figure 53 - Step 5 Loosen reservoir insulation

6. Route the float switch cable between the front thermoelectric subassembly bracket and the power supply (Figure 54).

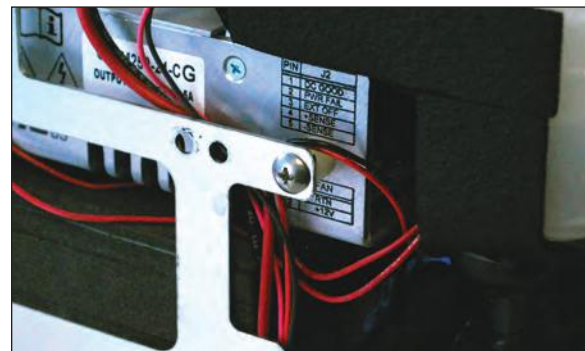

Figure 54 - Step 6 Route wiring behind bracket

Operation & Service Manual

7. Connect the float switch cable to J7 on the control board (Figure 55).
8. Follow instructions for section 21.2 Front Enclosure Installation, on page 45.
9. Perform a leak test with the unit running (section 18.2 on page 28).
10. Follow instructions for section 18.4 Low Water Switch/Indicator Test, on page 29.
11. Perform the maintenance as required in 19.0 Preventive Maintenance for Service Personnel, on page 33.
12. Follow instructions for section 20.2 Rear Enclosure and Reservoir Lid Installation, on page 41).



Figure 55 - Step 7 Attach connector to J7



Reservoir

26.0 Reservoir Replacement



CAUTION: Working with electronic boards, plugs, and cables requires delicate handling. Proper Electrostatic Discharge (ESD) procedures should be followed during replacement of any electronic board. Failure to do so may result in damage to the board.

Tools required:

- 1/4" nut driver
- Slotted screwdriver

Parts provided:

- Reservoir
- Reservoir insulation kit

Parts not provided:

- Black electrical tape



Reservoir Kit

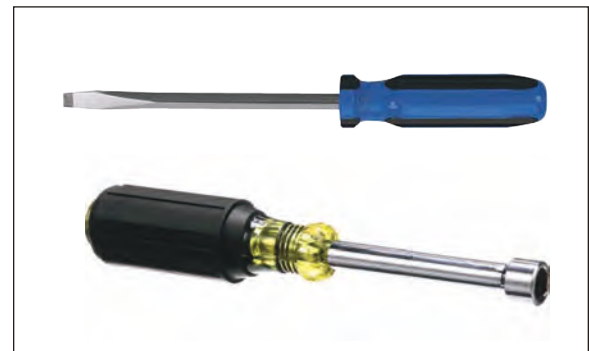

Tools

Operation & Service Manual

26.1 Reservoir Removal

1. Follow instructions for section 20.0 Rear Enclosure and Reservoir Lid Replacement, on page 38.
2. Follow instructions for section 21.0 Front Enclosure Replacement, on page 43.
3. Follow instructions for section 25.0 Float Switch Replacement, on page 56.
4. Remove the electrical tape and insulation wrapped around the hose clamps.
5. Use the slotted screwdriver to loosen the two hose clamps at the tubing connection to the reservoir (Figure 56).

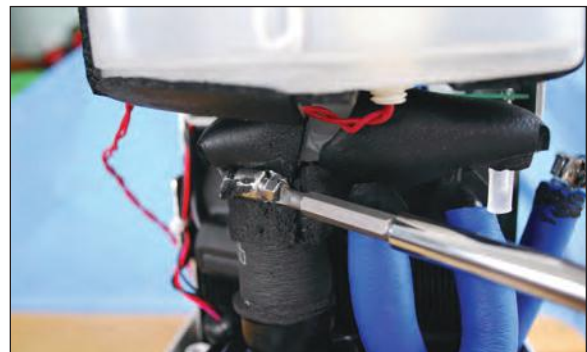

Figure 56 - Step 5 Loosen two hose clamps

6. Remove the tubing at each of the two connections from the reservoir.

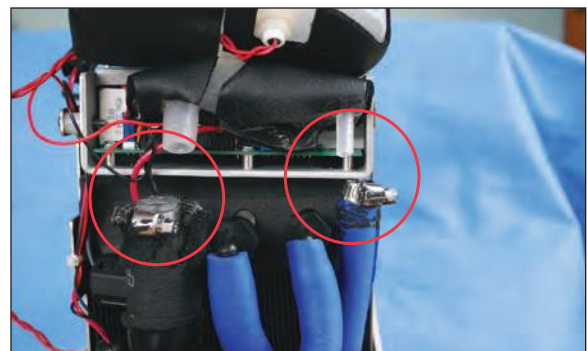

Figure 57 - Step 6 Remove tubing

26.2 Reservoir Installation

1. Install tubing onto new reservoir and secure with hose clamps.
2. Follow instructions for securing the float switch into the new reservoir, section 25.0 Float Switch Replacement, on page 56.
3. Position the float switch cable under the reservoir. Then wrap the primary and secondary reservoirs with 1/8" thick insulation. Ensure the float switch wires come out towards the front left corner of the reservoir.
4. Connect the float switch connector to J7 on the control board.
5. Follow instructions for section 21.2 Front Enclosure Installation, on page 45).
6. Perform a leak test with the unit running (section 18.2 on page 28).
7. Check for kinks in the water tubing.
8. Perform the maintenance as required in Table 5. Preventive Maintenance Inspection Sheet, on page 33.
9. Refer to installation of rear enclosure (section 20.2 Rear Enclosure and Reservoir Lid Installation, on page 41).



Figure 58 - Step 1 connect tubing to reservoir with clamps

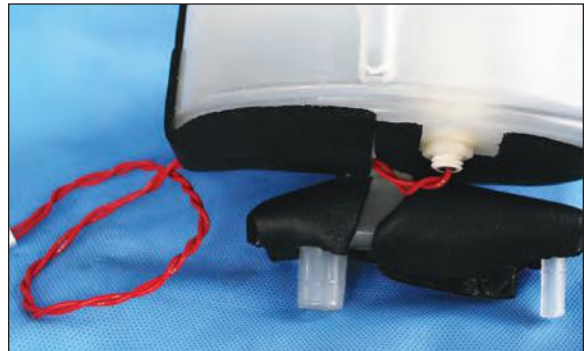

Figure 59 - Step 3 Float switch wires position

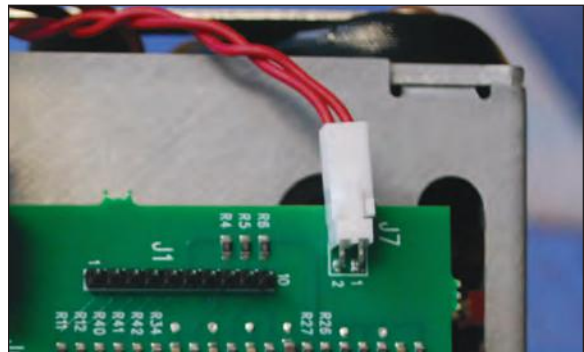

Figure 60 - Step 4 Connect float switch to J7

Operation & Service Manual



Pump kit

27.0 Pump Replacement



CAUTION: Working with electronic boards, plugs, and cables requires delicate handling. Proper Electrostatic Discharge (ESD) procedures should be followed during replacement of any electronic board. Failure to do so may result in damage to the board.

Tools required

- # 2 Phillips screwdriver
- Slotted screwdriver
- Wire cutter

Parts supplied

- Pump Kit



Tools

27.1 Pump Removal

1. Refer to section 20.0 Rear Enclosure and Reservoir Lid Replacement, on page 38.
2. Refer to section 21.0 Front Enclosure Replacement, on page 43.
3. Disconnect the pump connector from J5 on the control board (Figure 61).

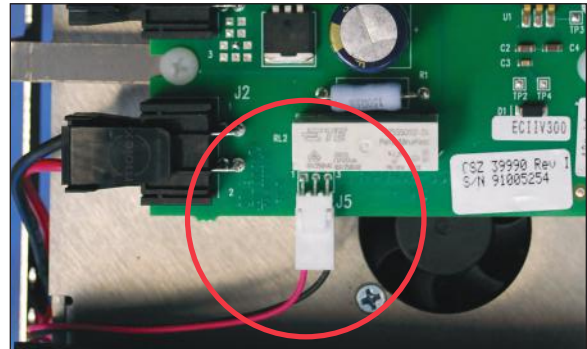

Figure 61 - Step 3 Unplug pump wiring

4. Remove the wire tie holding the fan and pump wires to the thermoelectric subassembly bracket (Figure 62).

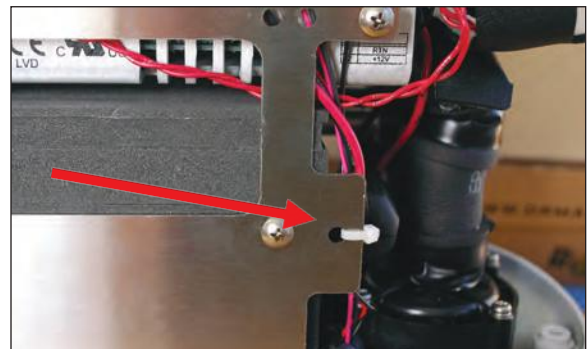

Figure 62 - Step 4 Remove the wire tie

5. Remove the Electro-magnetic interfferrance (EMI) suppressor that is around the fan and pump wires (Figure 63).

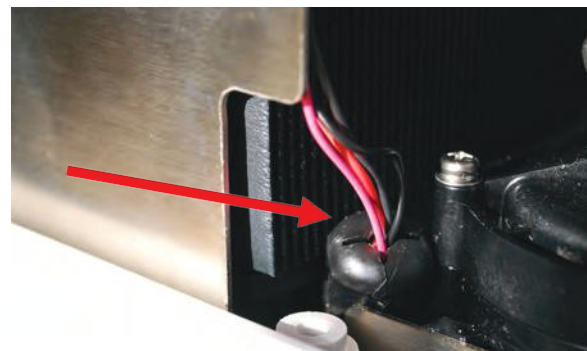

Figure 63 - Step 5 Remove EMI suppressor

Operation & Service Manual

6. Remove discharge tubing from the pump.



Figure 64 - Step 7 Remove discharge tubing

7. Use the slotted screwdriver to loosen the two hose clamps at the tubing connection to the reservoir

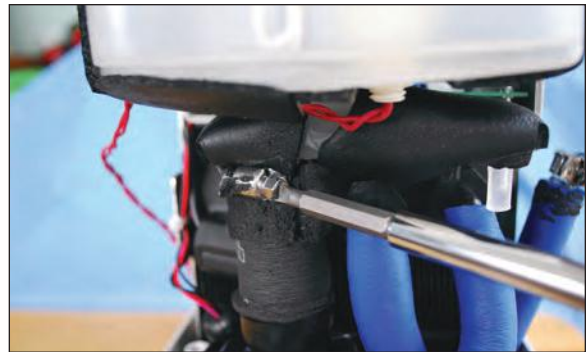

Figure 65 - Step 5 Loosen two hose clamps

8. Remove pump mount bracket from the base by removing two Phillips screws (Figure 66). Do not discard the screws.



Figure 66 - Step 6 Unscrew pump bracket from base enclosure

Service

Electri-Cool II Model 767

9. Remove inlet tubing from the pump.



Figure 67 - Step 8 Remove inlet tubing

10. Use a #2 Phillips screwdriver to remove pump from the bracket (Figure 68).

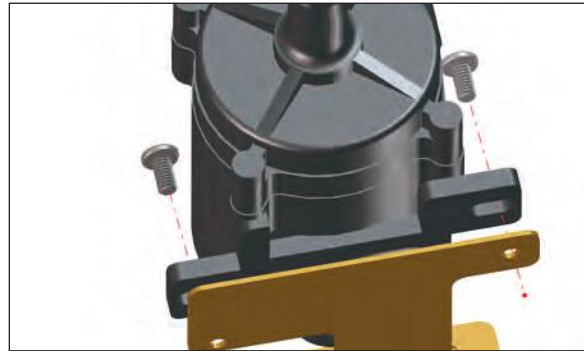

Figure 68 - Step 1 Remove pump from bracket

Operation & Service Manual

27.2 Pump Installation

1. Mount new pump to the new pump bracket using two #8-32 x 5/16" Phillips screws (Figure 69).

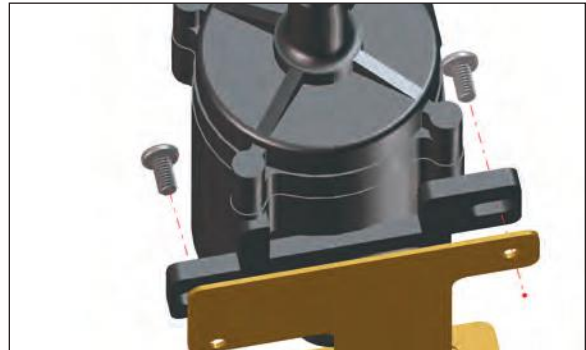

Figure 69 - Step 1 Mount pump to bracket

2. Mount pump bracket to the base enclosure using two #8-32 x 1/2" flat-head screws (Figure 70).

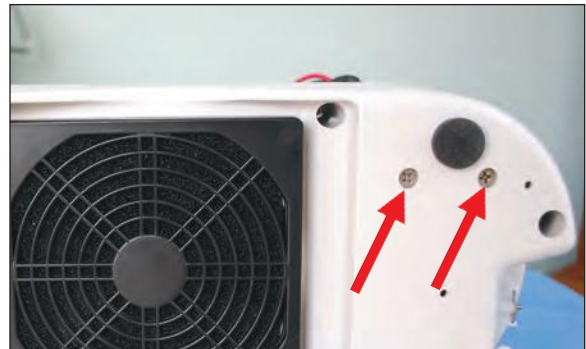

Figure 70 - Step 2 Mount bracket to base

3. Slide the discharge and inlet tubing all the way onto the new pump (Figure 71).

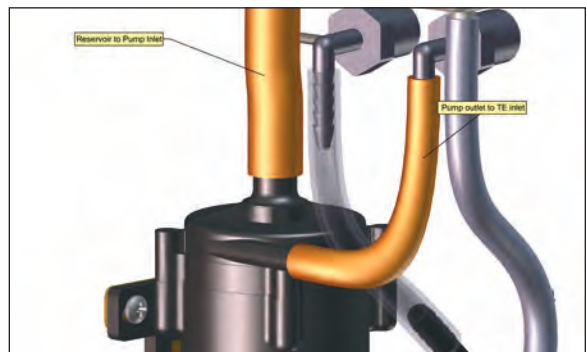

Figure 71 - Step 3 slide tubing onto new pump

Service

Electri-Cool II Model 767

4. Use the slotted screwdriver to tighten the two hose clamps at the tubing connection to the reservoir.

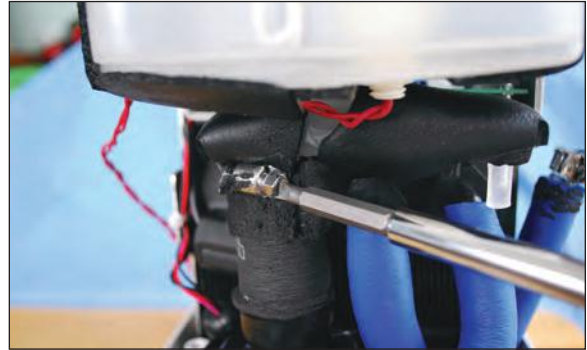

Figure 72 - Step 4 Tighten the hose clamps.

5. Install the EMI suppressor around the fan and pump wires (Figure 73).

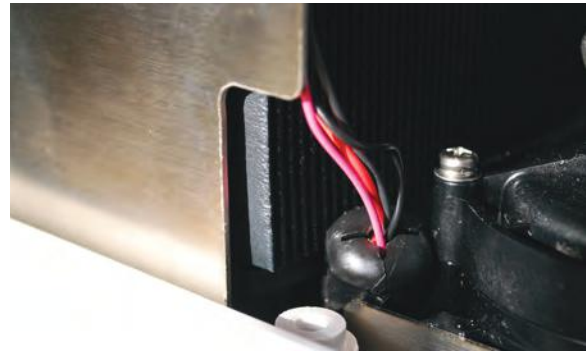

Figure 73 - Step 5 Install EMI suppressor

6. Slide the EMI suppressor up on the wires, and fasten the fan and pump wires together with a wire tie as close to the pump as possible but below the EMI suppressor (Figure 74). Use the wire cutters to remove the excess wire tie.

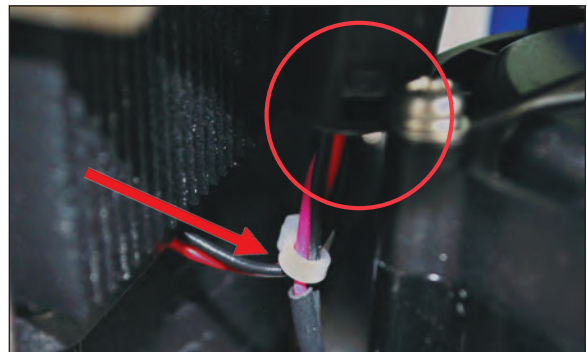

Figure 74 - Step 6 Wire tie below EMI suppressor

Operation & Service Manual

- Secure the fan and pump wires to the front thermoelectric subassembly bracket with a wire tie (Figure 75). Use the wire cutters to remove the excess wire tie. Slide the EMI suppressor down to the wire tie.

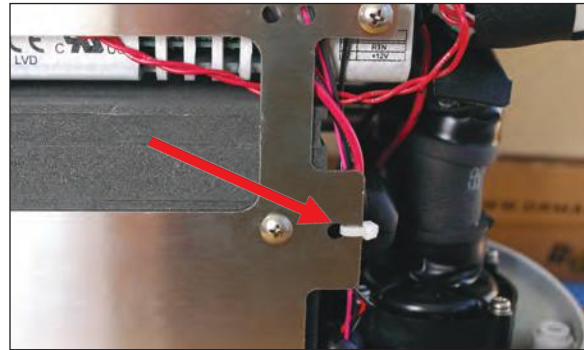

Figure 75 - Step 7 Secure wires to bracket

- Route the pump and fan wires between the power supply and the thermoelectric subassembly bracket (Figure 76). Make sure the fan wires are tucked into the same location with the pump wiring.

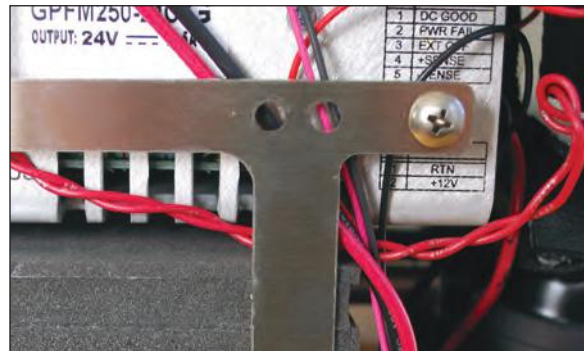

Figure 76 - Step 8 Route wires behind bracket

- Connect the pump power wire connector to J5 on the control board.
- Follow instructions for section 21.2 Front Enclosure Installation, on page 45.
- Perform a leak test with the unit running (section 18.2 on page 28).
- Follow instructions for section 20.0 Rear Enclosure and Reservoir Lid Replacement, on page 38.
- Perform the maintenance as defined in 19.0 Preventive Maintenance for Service Personnel, on page 33).

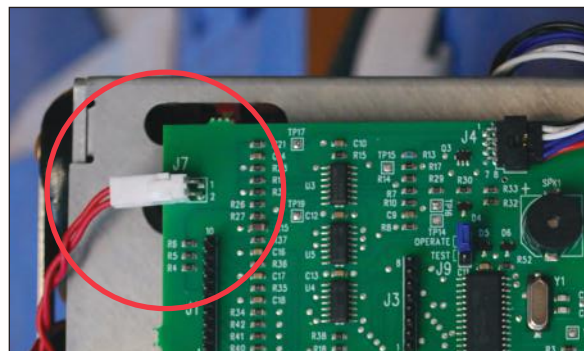
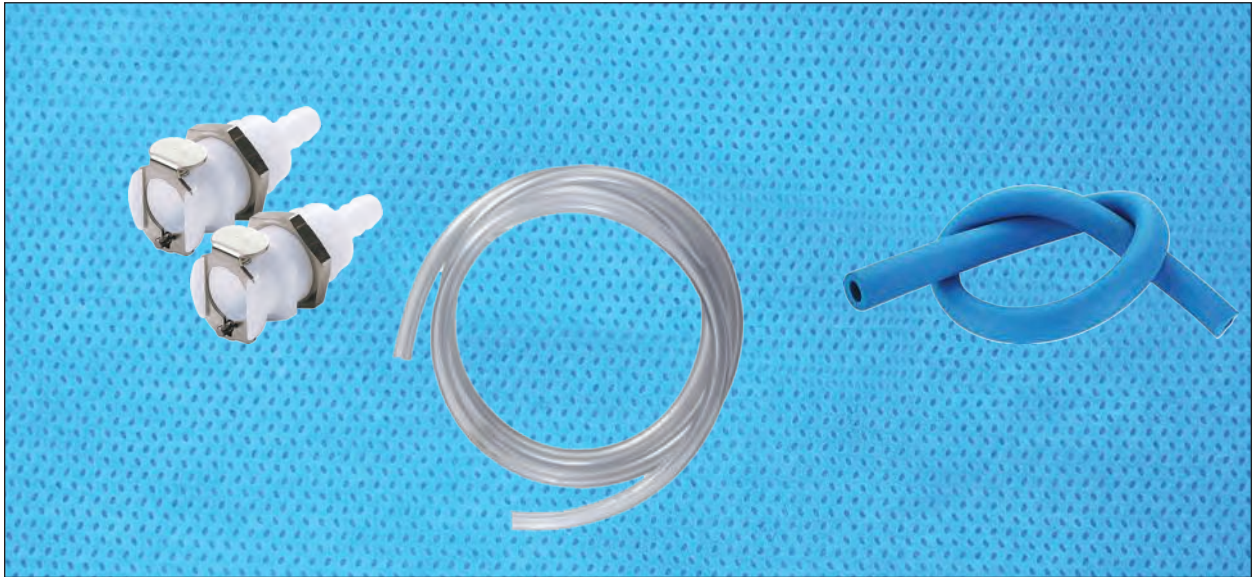

Figure 77 - Step 9 Connect power wire connector to J5



Quick disconnect panel mount couplings

28.0 Quick Disconnect Panel Mount Couplings Replacement

Tools:

- 3/4" open end wrench
- 13/16" open end wrench
- Heat gun
- Tubing cutter

Parts supplied:

- One foot of clear PVC Tubing 1/4" ID x 3/8" OD from Gentherm
- One foot of Insulation Tubing, 3/8" ID x 1/8 W from Gentherm



Tools

Operation & Service Manual

28.1 Quick Disconnect Removal

1. Follow instructions for section 20.1 Rear Enclosure and Reservoir Lid Removal, on page 39.
2. Follow instructions for section 21.1 Front Enclosure Removal, on page 44.
3. Use the heat gun to soften the tubing at the couplings. With your fingers, remove the tubing from the couplings.
4. Use the heat gun to soften the tubing at the pump 90 degree elbow.

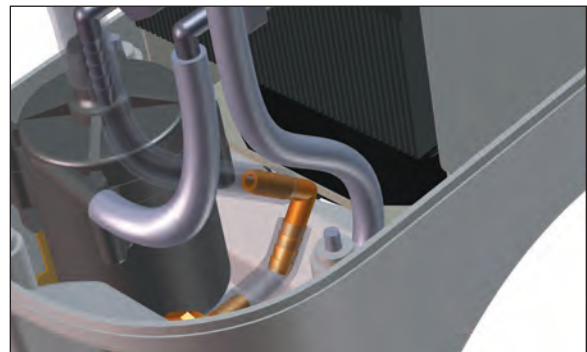

Figure 78 - Step 4 Tubing at 90 degree elbow

5. Use the heat gun to soften the tubing at the pump. With your fingers, remove the tubing from the pump and reservoir locations.

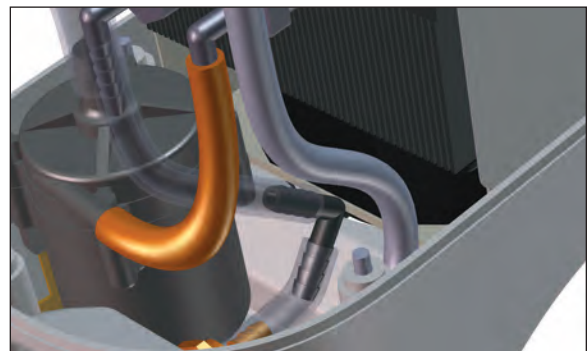

Figure 79 - Step 5 Remove tubing from pump

Service

Electri-Cool II Model 767

6. Use the 3/4" wrench to unscrew the retainer nuts on the back of the quick disconnect couplings (Figure 80). Slide the nuts up onto the tubing.

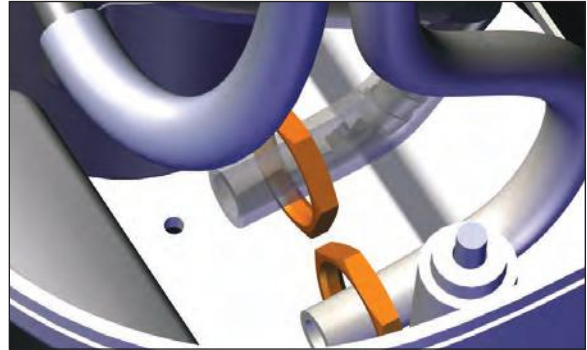

Figure 80 - Step 6 Slide retainer nuts up

7. Pull the quick disconnect couplings out of the bottom enclosure.
8. Cut or remove the PVC tubing behind each of the quick disconnect couplings.
9. Discard the old PVC tubing and Insulation tubing.

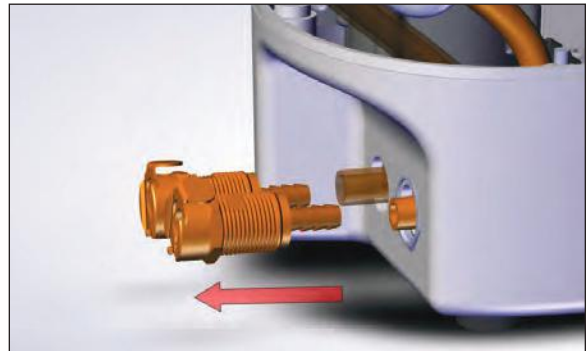

Figure 81 - Step 7 Pull couplings out of enclosure

Operation & Service Manual

28.2 Quick Disconnect Installation

1. Cut a 2 inch length of PVC tubing and install it on the 90 degree hose barb.
2. Cut a 2-1/2 inch length of Insulation tubing and slide it over the 2 inch PVC tube.
3. Cut a 6-1/2 inch length of PVC tubing and install it on the reservoir barbed connector
4. Cut a 6-1/2 inch length of Insulation tubing and slide it over the 6-1/2 inch PVC tube.
5. Slip the quick disconnect retaining nuts onto the ends of the tubing just installed (Figure 82).

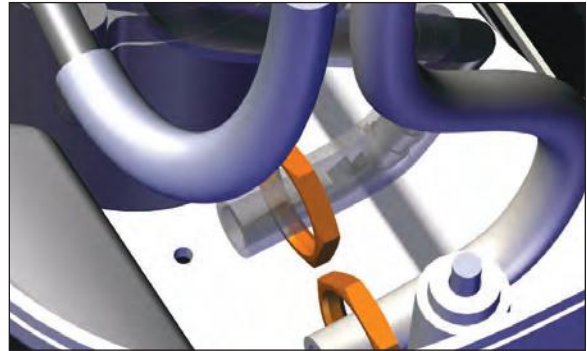

Figure 82 - Slide retainer nuts onto tubing

6. Extend the two lengths of tubing through the appropriate openings in the base enclosure (Figure 83).

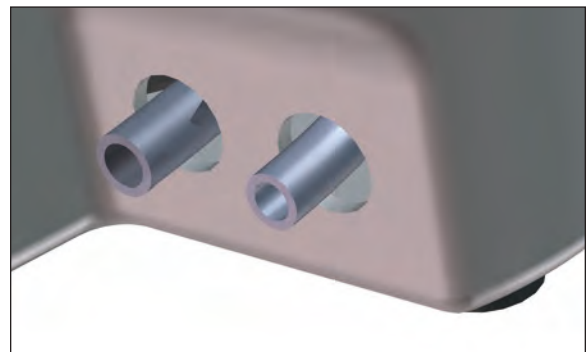

Figure 83 - Step 6 Extend tubing through enclosure

Service

Electri-Cool II Model 767

7. Heat the PVC tubing ends and push them onto the quick disconnects (Figure 84).

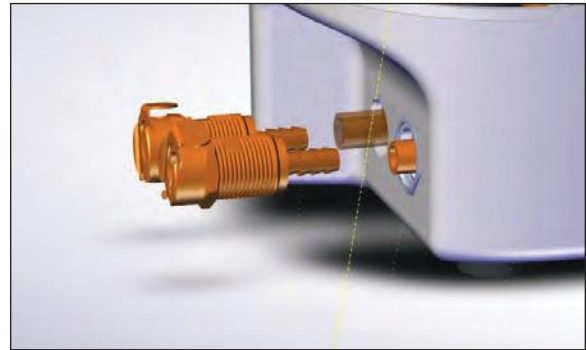

Figure 84 - Step 7 Insert couplings into hose

8. Push the quick disconnect couplings through the openings in the base enclosure. Turn them so the release button is facing up. Check for kinks in the tubing.

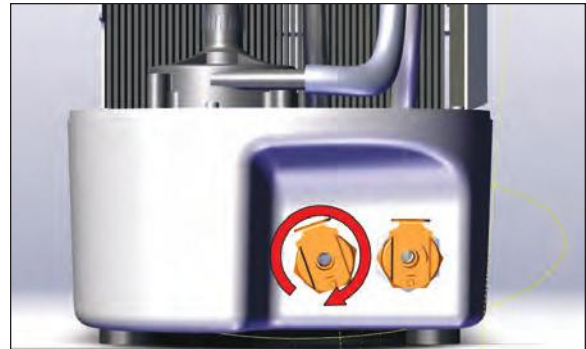

Figure 85 - Step 8 Turn and align couplings

Operation & Service Manual

9. Thread the retaining nuts onto the threads and tighten with the open end wrench.

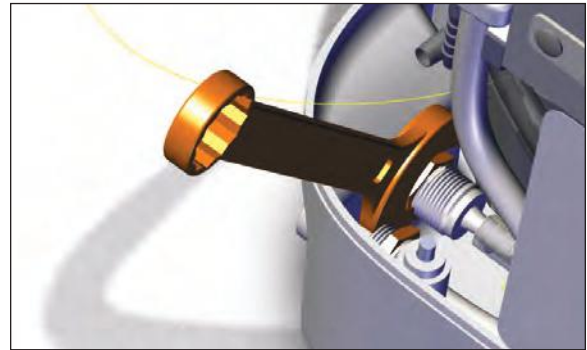

Figure 86 - Step 9 Tighten retaining nuts

10. Perform a leak test of the tubing connections (section 18.2 on page 28).

11. Tape up the exposed clamps with insulation tape.

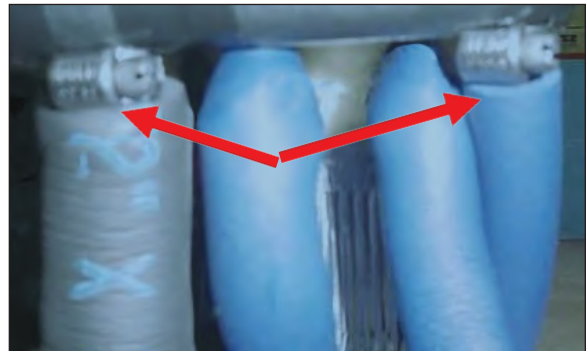

Figure 87 - Step 11 Tape the exposed clamps

12. Apply electrical tape around insulation tape (Figure 88).

13. Follow instructions for section 21.2 Front Enclosure Installation, on page 45.

14. Follow instructions for section 20.2 Rear Enclosure and Reservoir Lid Installation, on page 41.



Figure 88 - Step 12 Apply electrical tape around insulation



Fuses

29.0 Fuse Replacement

Tools:

- 1/8 inch slotted screwdriver



Tools

Parts provided:

- Fuses (requires two)



CAUTION: Working with electronic boards, plugs, and cables requires delicate handling. Proper Electrostatic Discharge (ESD) procedures should be followed during replacement of any electronic component.

Operation & Service Manual

29.1 Fuse Removal

1. Disconnect the device from any power source (Figure 89).

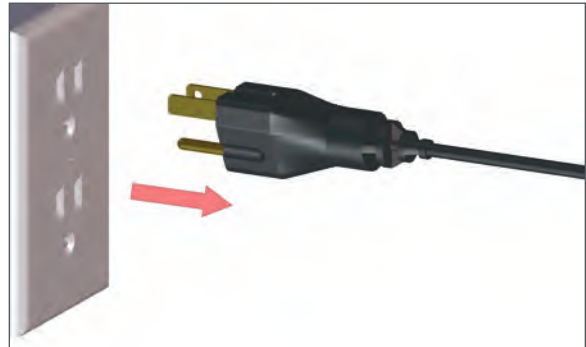

Figure 89 - Step 1 Unplug power

2. Locate the slot at the top of the power inlet and use a screw driver to pry the fuse door open (Figure 90).



Figure 90 - Step 2 Open fuse door

3. Note that the direction arrows on the access door match the arrows on the slide out fuse holders (Figure 91).
4. One fuse is in each of the two slide out fuse holders. Pull the fuse holders out to access the fuse.



Figure 91 - Step 3 Note direction arrows

29.2 Fuse Installation

1. Replace the fuse with the replacement fuse from Gentherm. Place each fuse into a fuse holder.

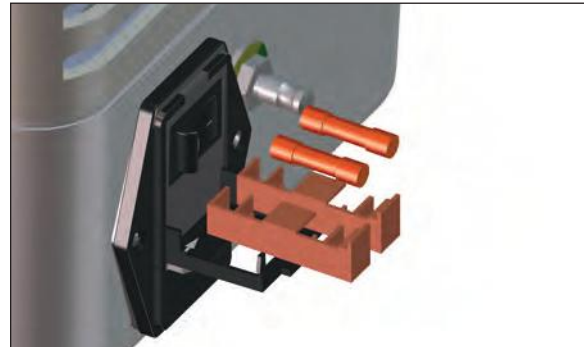

Figure 92 - Step 1 Place fuses into holders

2. Match the fuse holder arrow direction to the arrows on the access door. Push the fuse holder back into its original position (Figure 93).



Figure 93 - Step 2 Match arrow direction

3. Push the fuse door closed until it snaps in place. Make sure the lock tabs are inside the enclosure (Figure 94).
4. Attach a pad to the device.
5. Turn on the Electri-Cool II.
6. Check that the device will sustain power when it is in 5-7 °C cooling mode.

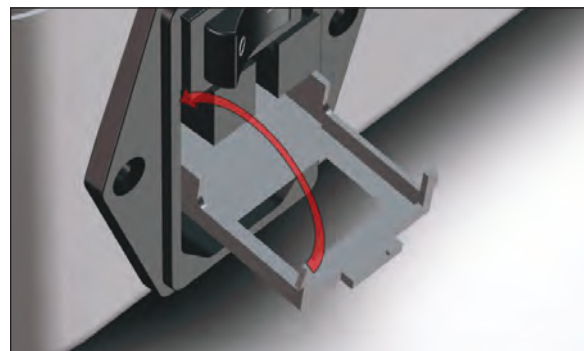
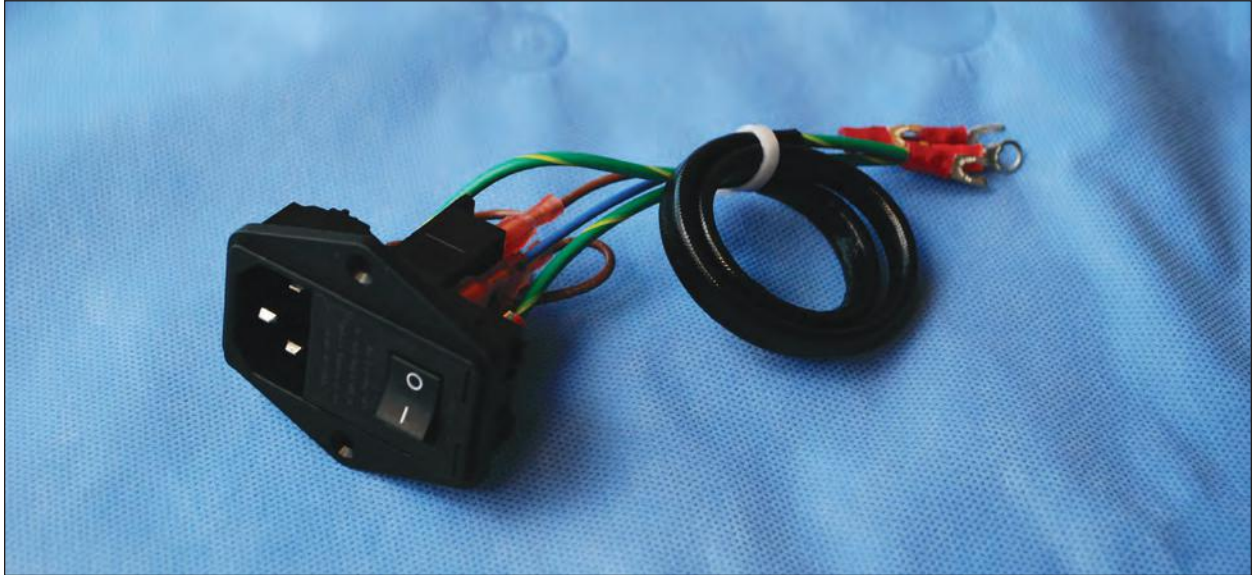

Figure 94 - Step 3 Locking tabs



Power inlet and wire harness

30.0 Power Inlet and Wire Harness Replacement



CAUTION: Working with electronic boards, plugs, and cables requires delicate handling. Proper Electrostatic Discharge (ESD) procedures should be followed during replacement of any electronic board. Failure to do so may result in damage to the board.

Tools:

- #2 Phillips screwdriver
- 11/32" open end wrench
- 10 mm open end x 2

Parts provided:

- Wire harness with power inlet



Tools

30.1 Power Inlet Removal

1. Follow instructions for section 20.1 Rear Enclosure and Reservoir Lid Removal, on page 39.
2. Follow instructions for section 21.1 Front Enclosure Removal, on page 44.
3. Remove the power inlet plastic shroud (Figure 95).

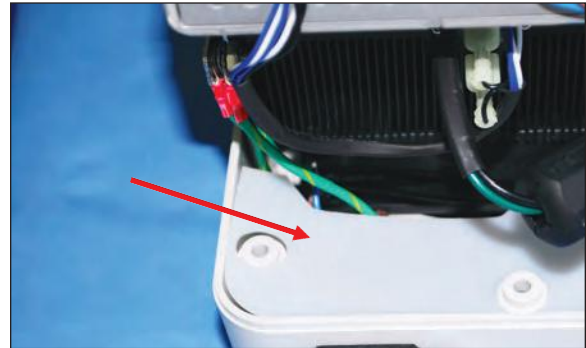

Figure 95 - Step 3 Plastic power inlet shroud

4. Remove the retaining Keps nut and remove all ground wires from the grounding post to free the power inlet wire harness (Figure 96).

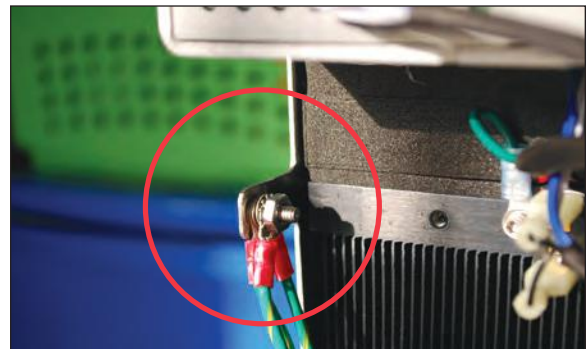

Figure 96 - Step 4 Remove retaining Keps nut and ground wires

Operation & Service Manual

5. Disconnect the power inlet wire harness from the power supply (Figure 97).

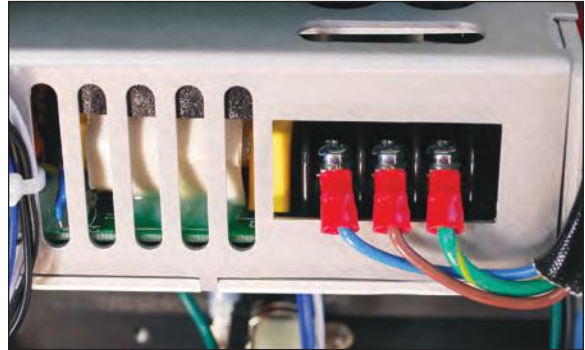

Figure 97 - Step 5 Disconnect harness from the power supply

6. Remove the EMI suppressor from the control board power wire.



Figure 98 - Step 6 Remove suppressor

Service

Electri-Cool II Model 767

7. Remove the two retaining screws and small Keps nuts that mount the power inlet to the bottom enclosure (Figure 99). Do not discard the screws and nuts.



Figure 99 - Step 7 Remove retaining screws

8. Pull the power inlet out from the bottom enclosure (Figure 100).

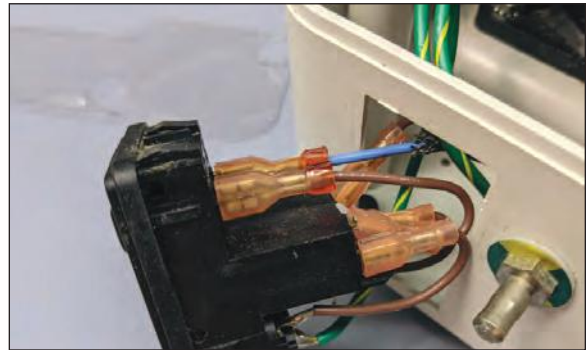

Figure 100 - Step 8 Power inlet removal 2

Operation & Service Manual

30.2 Power Inlet Installation

1. Follow instructions for section 29.2 Fuse Installation, on page 79.
2. Install new power inlet using two (2) #4-40 x 3/4" screws and two (2) #4-40 Keps nuts (Figure 101).



Figure 101 - Step 2 Install power inlet

3. Connect the control board power wires to connector J2.

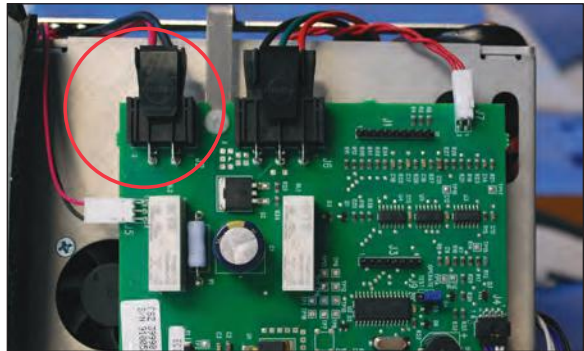

Figure 102 - Step 3 Connect control board wires to J2

4. Install the EMI suppressor on the control board power wire that goes to J2 (Figure 103).

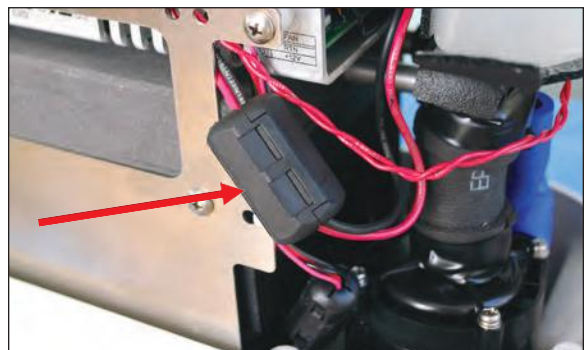

Figure 103 - Step 4 Install EMI suppressor

Service

Electri-Cool II Model 767

5. Route the new wire harness connector behind the thermoelectric subassembly bracket (Figure 104).

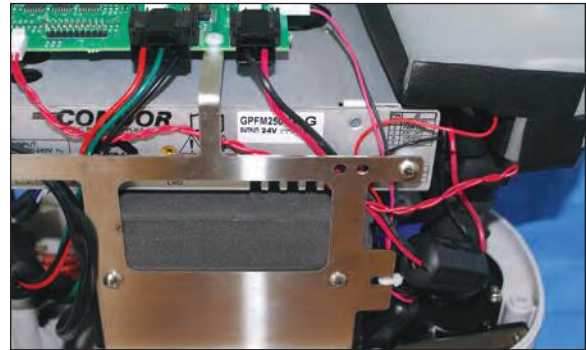

Figure 104 - Step 5 Route wire harness connector behind bracket

6. Connect the power supply to the three wires that come from the power inlet (Figure 105).

- Pin three to green wire
- Pin two to brown wire
- Pin one to blue wire

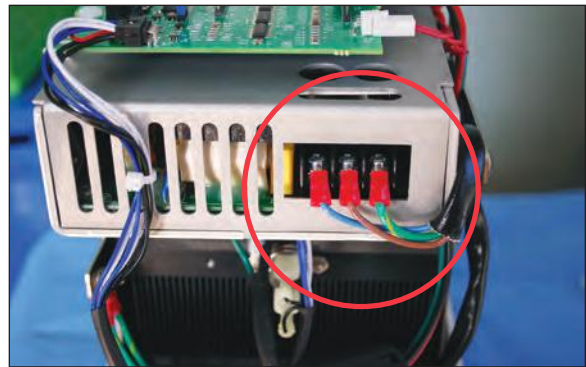

Figure 105 - Step 6 Connect power supply

7. Connect all ground wires to the grounding post (Figure 106).

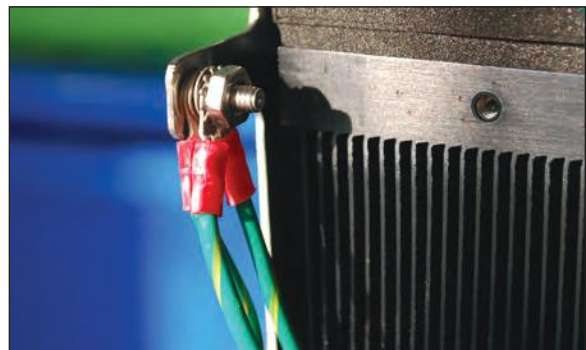

Figure 106 - Step 7 Attach all grounding wires

Operation & Service Manual

8. Reinstall the power inlet plastic shroud.
9. Follow instructions for section 21.2 Front Enclosure Installation, on page 45.
10. Perform the maintenance as defined in the “Preventive Maintenance for Service Personnel” on page 33.
11. Follow instructions for section 20.2 Rear Enclosure and Reservoir Lid Installation, on page 41.

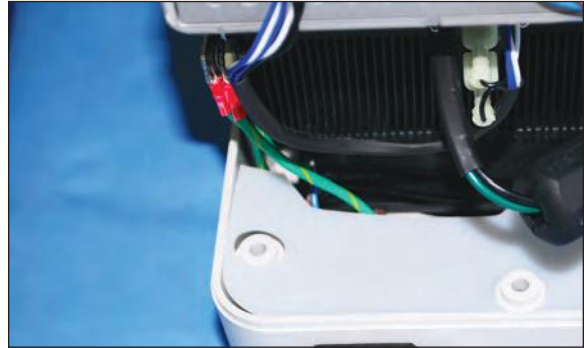
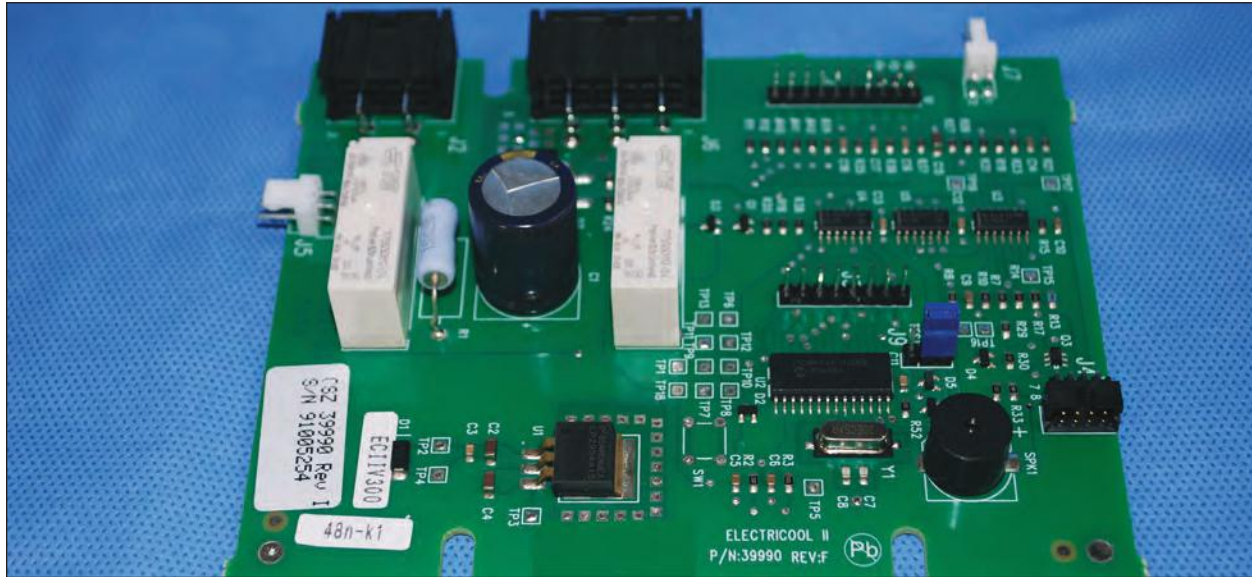

Figure 107 - Step 8 Reinstall plastic power inlet shroud



Control Board

31.0 Control Board Replacement



CAUTION: Working with electronic boards, plugs, and cables requires delicate handling. Proper Electrostatic Discharge (ESD) procedures should be followed during replacement of any electronic board. Failure to do so may result in damage to the board.

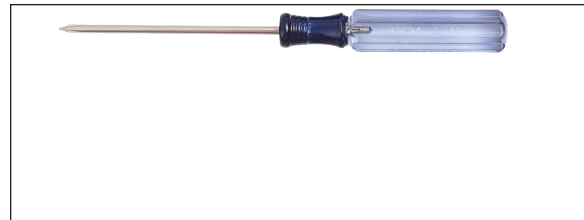

Tools

Tools:

- #2 Phillips screwdriver

Parts provided:

- Control board

Operation & Service Manual

31.1 Control Board Removal

1. Refer to section 20.0 Rear Enclosure and Reservoir Lid Replacement, on page 38.
2. Refer to section 21.0 Front Enclosure Replacement, on page 43.
3. Disconnect all five (5) electrical connectors from the control board (Figure 108).

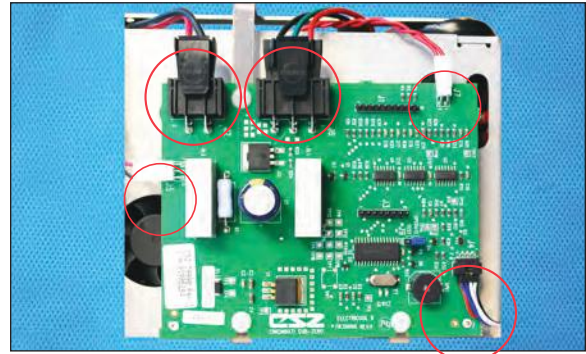

Figure 108 - Step 3 Disconnect all 5 connectors

4. Remove three plastic screws (Figure 109).

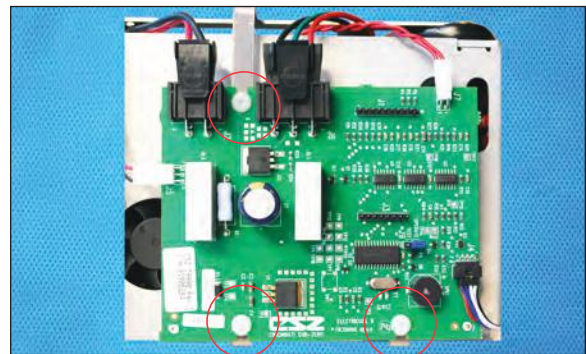

Figure 109 - Step 4 Remove three plastic screws

5. Remove the three (3) plastic washers located between the control board and the thermoelectric bracket assembly at the same locations as the plastic screws (Figure 110). Do not discard. Set them aside for reuse.
6. Remove the control board.

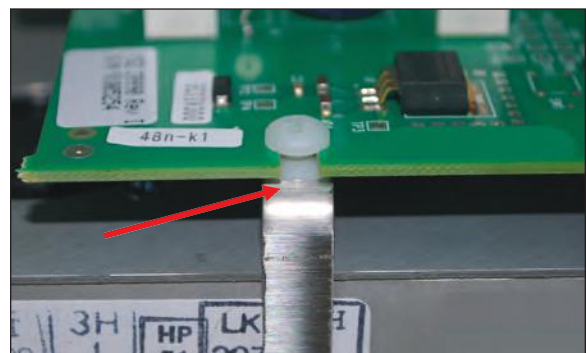

Figure 110 - Step 5 Remove three plastic washers (one shown)

31.2 Control Board Installation

1. Reinstall the three #8 plastic washers onto the thermoelectric bracket assembly (Figure 112).

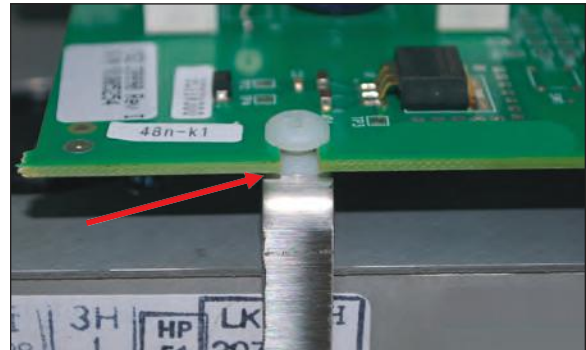

Figure 111 - Step 1 Remove three plastic washers (one shown)

2. Place the new control board in place and install the three #8-32 x 1/4 " plastic Phillips screws to hold the board in place (Figure 112).

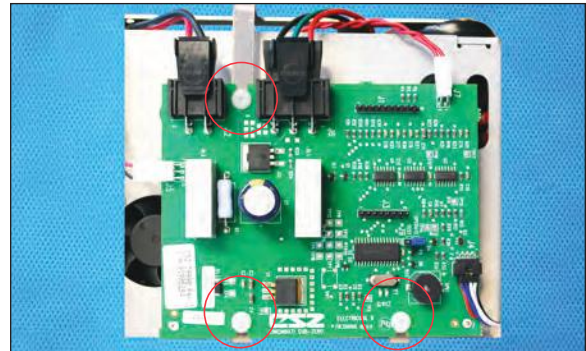

Figure 112 - Step 2 Reinstall three plastic screws

3. Connect all five (5) electrical connectors to the control board (Figure 113).
4. Follow instructions for section 21.2 Front Enclosure Installation, on page 45.
5. Perform the maintenance as defined in the "Preventive Maintenance for Service Personnel" on page 33.
6. Refer to section 20.2 Rear Enclosure and Reservoir Lid Installation, on page 41.

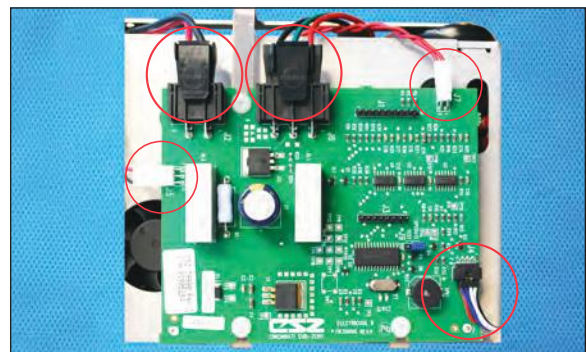

Figure 113 - Step 3 Connect all 5 connectors



Power Supply

32.0 Power Supply Replacement



CAUTION: Working with electronic boards, plugs, and cables requires delicate handling. Proper Electrostatic Discharge (ESD) procedures should be followed during replacement of any electronic board. Failure to do so may result in damage to the board.



Tools

Tools:

- #2 Phillips screwdriver

Parts provided:

- Power supply
- Wire ties

32.1 Power Supply Removal

1. Refer to section “Rear Enclosure and Reservoir Lid Replacement” on page 38.
2. Refer to section “Front Enclosure Replacement” on page 43.
3. Follow instructions for section 31.1 Control Board Removal, on page 88.
4. Remove the two Phillips, truss-head screws and two spacers holding the power supply to the thermoelectric subassembly front bracket. Set them aside for re-use.
5. Remove the 2 Phillips screws holding the power supply to the TE rear bracket. Set them aside for re-use.
6. Disconnect the control board power wire harness and fan wires from the power supply.



Figure 114 - Step 4 Unscrew power supply from front bracket

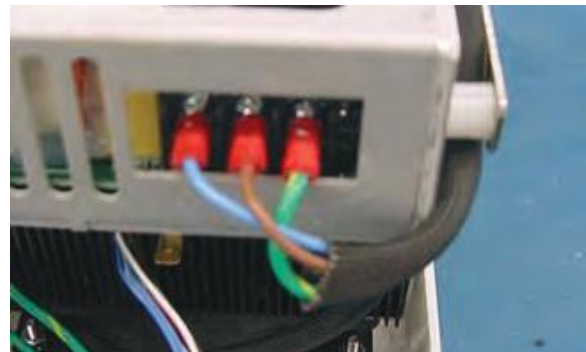

Figure 115 - Step 5 Control board power wire harness

Operation & Service Manual

7. Remove the two Phillips, truss-head screws and two spacers (if present) holding the power supply to the thermoelectric subassembly rear bracket.

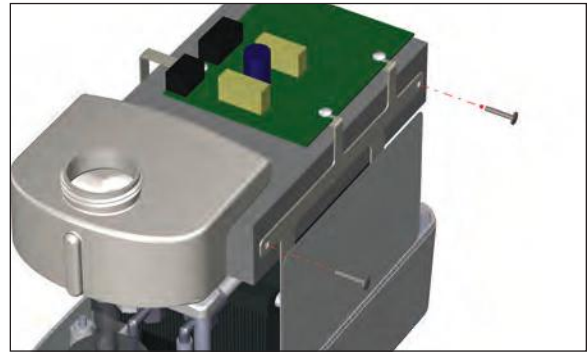

Figure 116 - Step 6 Remove Phillips screws from rear bracket.

8. Use the Phillips screwdriver to disconnect the power supply from the three wires that come from the power inlet.

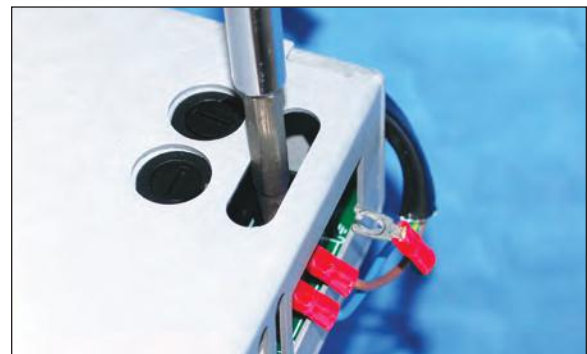

Figure 117 - Step 7 Disconnect power supply wires to power inlet

9. Remove the wire tie holding the wires to the power supply.

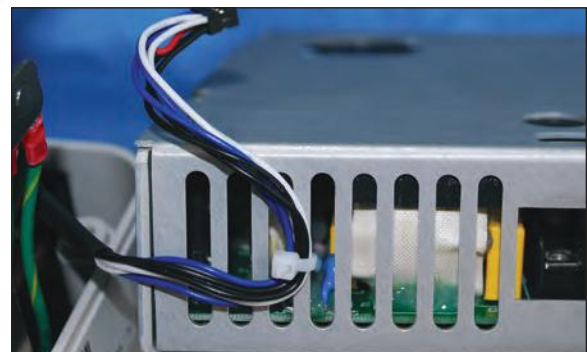

Figure 118 - Step 8 Remove wire tie on power supply

32.2 Power Supply Installation

1. Connect the power supply to the three wires that come from the power inlet (Figure 119).
 - Connect the blue wire to pin one
 - Connect the brown wire to pin two
 - Connect the green wire to pin three

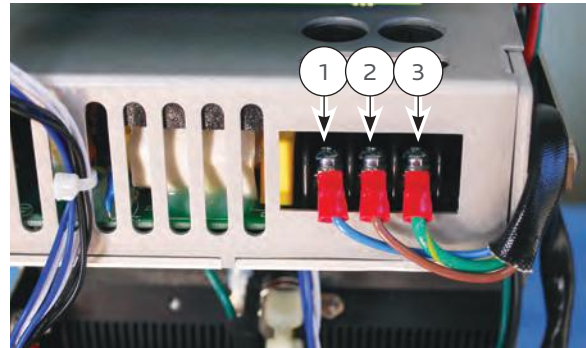

Figure 119 - Step 1 Connect power supply wires from power inlet

2. Secure the power supply by installing with two #8-32 x 3/8" truss-head screws on the thermoelectric subassembly rear bracket. **Note:** Inspect all wire positions to ensure they are not pinched when tightening screws.

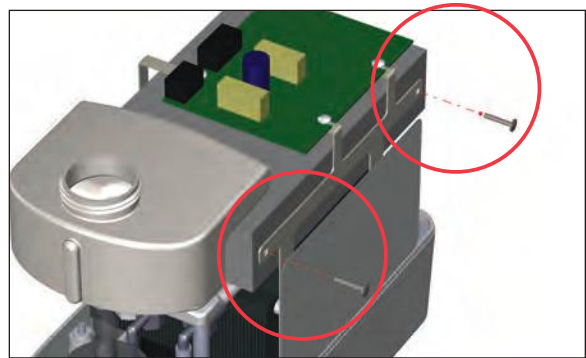

Figure 120 - Step 2 Install two truss-head screws on rear bracket

3. Connect the fan wires to the power supply (Figure 121).
 - Red wire to pin two
 - Black wire to pin four

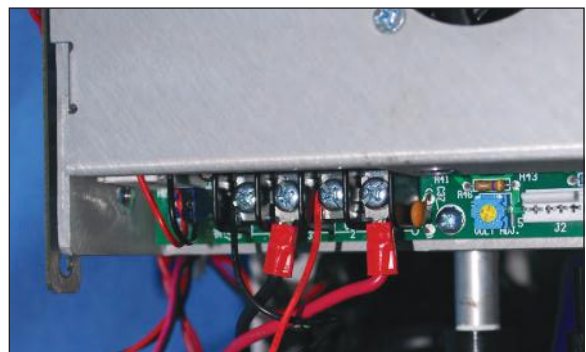

Figure 121 - Step 3 Connect fan wires to the power supply

Operation & Service Manual

4. Connect the control board power wire harness to the power supply (Figure 122).
 - Red wire to pin one
 - Black wire to pin three

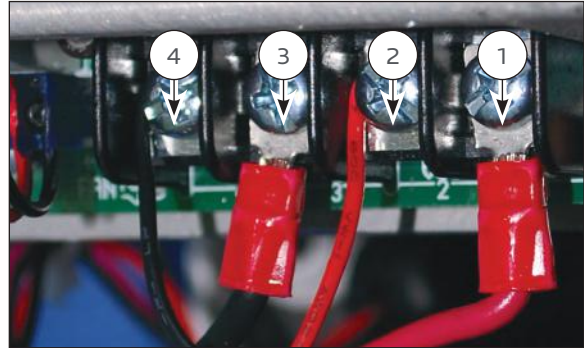

Figure 122 - Step 4 Detail

5. Make sure the power supply wires are placed between the power supply and the thermoelectric subassembly bracket (Figure 123).

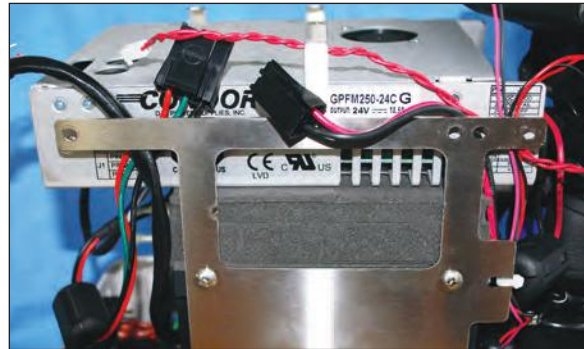

Figure 123 - Step 5 Power supply wires placement

6. Secure the power supply to the thermoelectric subassembly front bracket using two #8 x 3/8" spacers and two #8-32 x 3/4" Phillips truss-head screws (Figure 124).

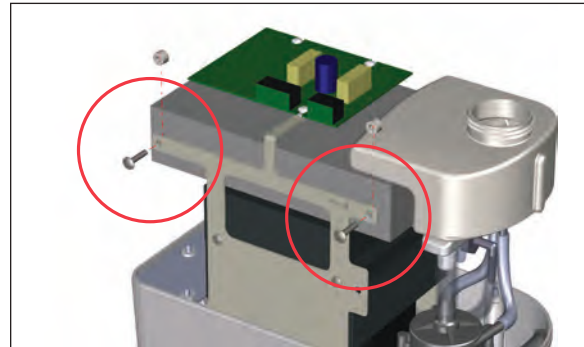

Figure 124 - Step 6 Secure power supply wires to front bracket

Service

Electri-Cool II Model 767

7. Wire tie the power supply wiring harness to the third slot on the side of the power supply (Figure 125).
8. Follow instructions for section 31.2 Control Board Installation, on page 89.
9. Follow instructions for section 21.2 Front Enclosure Installation, on page 45.
10. Perform the maintenance as defined in the “Preventive Maintenance for Service Personnel” on page 33.
11. Follow instructions for section 20.2 Rear Enclosure and Reservoir Lid Installation, on page 41.

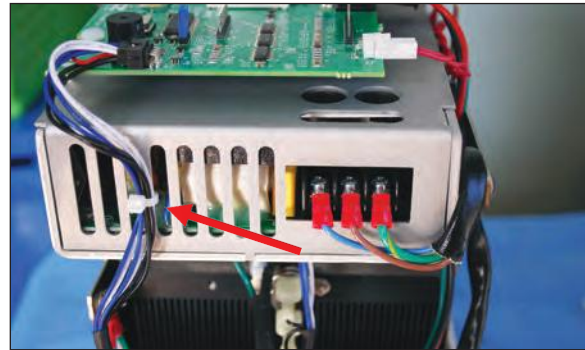

Figure 125 - Step 7 Wire tie the harness to the third slot



Thermoelectric Module

33.0 Thermoelectric (TE) Module Replacement



CAUTION: Working with electronic boards, plugs, and cables requires delicate handling. Proper Electrostatic Discharge (ESD) procedures should be followed during replacement of any electronic components.

Tools:

- #2 Phillips screwdriver

Parts provided:

- Thermoelectric module



Tools

33.1 TE Module Removal

1. Follow instructions for section 20.0 Rear Enclosure and Reservoir Lid Replacement, on page 38.
2. Follow instructions for section 21.0 Front Enclosure Replacement, on page 43.
3. Follow instructions for section 31.1 Control Board Removal, on page 88.
4. Follow instructions for section 32.1 Power Supply Removal, on page 91.
5. Remove two Phillips screws and the plastic spacers that attach the TE module on the front bracket (Figure 126). **Note:** Some ECII units do not have the plastic spacers.

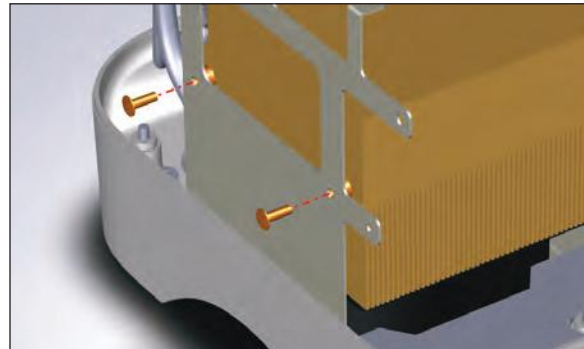

Figure 126 - Step 5 Remove screws and plastic spacers

6. Remove the two Phillips screws that attach the TE module on the back bracket.

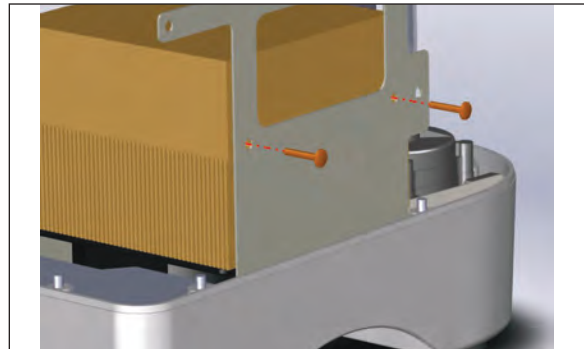

Figure 127 - Step 6 Remove two screws attaching the TE module to the back bracket

Operation & Service Manual

7. Remove the tubing from the TE module.
8. Lift the TE module out of the enclosure.

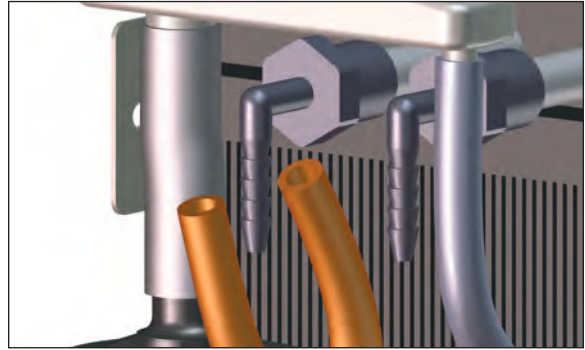

Figure 128 - Step 7 Remove tubing from TE module

33.2 TE Module Installation

1. Reconnect the tubing that goes from the TE module to the pump and quick disconnect (Figure 129).

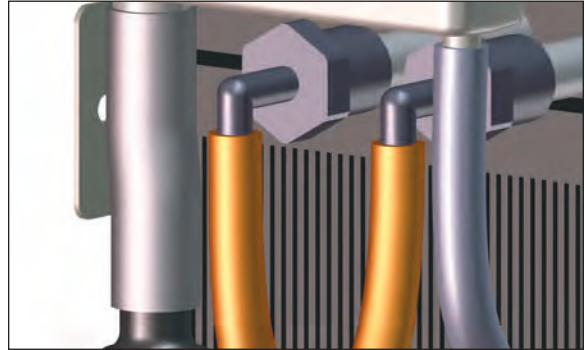

Figure 129 - Step 1 Reconnect TE tubing

2. Install the TE Module onto the **front bracket** with two #8-32 x 3/8" truss-head screws (Figure 130).

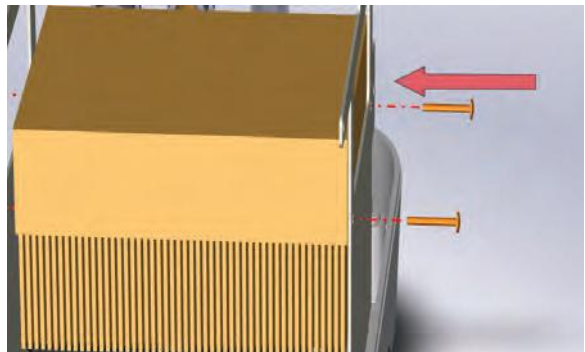

Figure 130 - Step 2 Install 2 screws attaching TE module to the front bracket

3. Install the TE Module with two #8-32 x 1/2" phillips screws and plastic spacers onto the **back bracket**. Spacers are installed **between** the TE module and the back thermoelectric subassembly bracket.

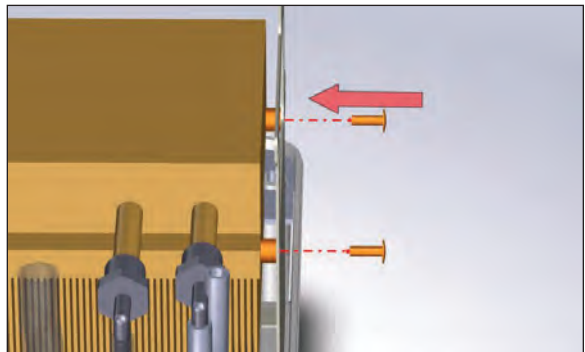

Figure 131 - Step 3 Install 2 screws and spacers

Operation & Service Manual

4. Follow instructions for section 32.2 Power Supply Installation, on page 93.
5. Follow instructions for section 31.2 Control Board Installation, on page 89.
6. Follow instructions for section 21.2 Front Enclosure Installation, on page 45.
7. Follow instructions for section 20.2 Rear Enclosure and Reservoir Lid Installation, on page 41.



Fan Motor

34.0 Fan Motor Replacement



CAUTION: Working with electronic boards, plugs, and cables requires delicate handling. Proper Electrostatic Discharge (ESD) procedures should be followed during replacement of any electronic board. Failure to do so may result in damage to the board.

Tools:

- #2 Phillips screwdriver
- 11/32" open end wrench

Parts provided:

- fan motor
- filter (optional)

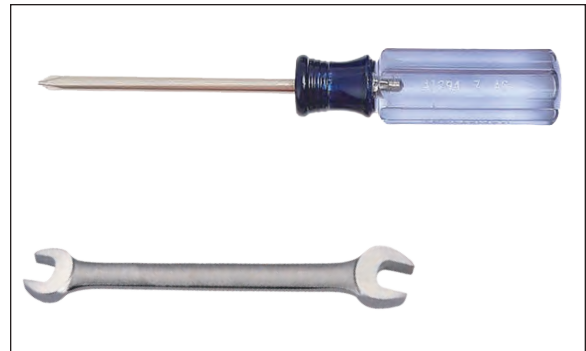

Tools

Operation & Service Manual

34.1 Fan Motor Removal

1. Follow instructions for section 20.0 Rear Enclosure and Reservoir Lid Replacement, on page 38.
2. Follow instructions for section 21.0 Front Enclosure Replacement, on page 43.
3. Follow instructions for section 31.1 Control Board Removal, on page 88.
4. Follow instructions for section 32.1 Power Supply Removal, on page 91.
5. Follow instructions for section 33.1 TE Module Removal, on page 97.
6. Follow instructions for section 35.1 Fan Guard Removal, on page 107. Remove the filter and filter retainer.
7. Remove the fan.

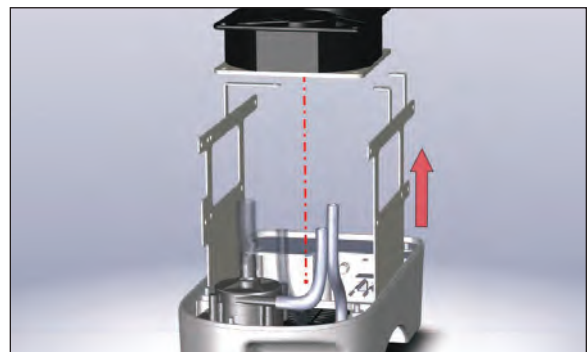

Figure 132 - Step 7 Remove the fan

8. The thermoelectric module (TE) brackets will be loose when the screws are removed. Set the brackets aside.

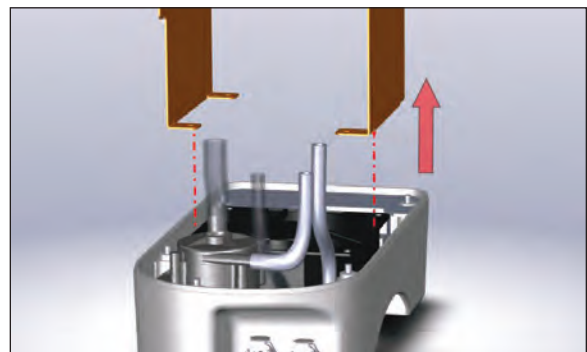

Figure 133 - Step 8 Remove brackets

34.2 Fan Motor Installation

1. Place four #8-32 x 1" phillips, oval-head screws into the fan guard screw holes.



Figure 134 - Step 1 Install four screws into fan guard holes

2. Install the Gentherm air filter into the filter retainer.

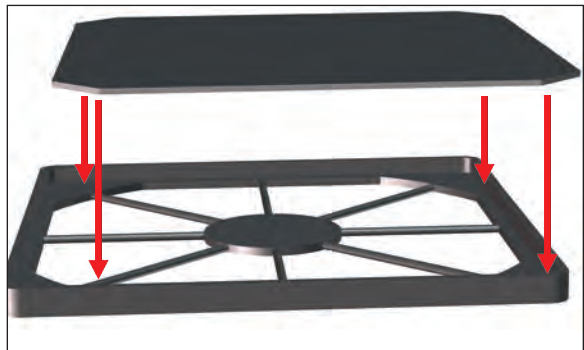

Figure 135 - Step 2 Place filter into retainer

3. Re-attach filter retainer to fan guard to hold screws in place when you put the fan motor on top of them.

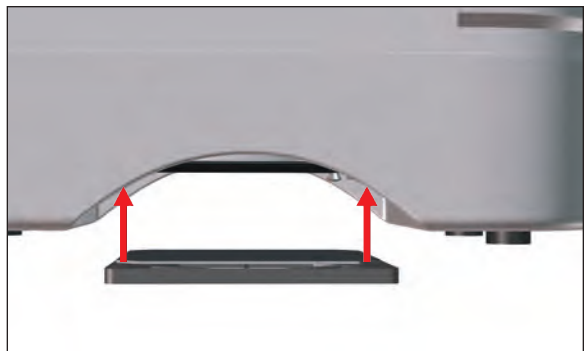

Figure 136 - Step 3 Re-attach filter retainer

Operation & Service Manual

4. Raise the bottom enclosure off of the table. Place a support under the fan guard so that the unit is suspended (Figure 137).

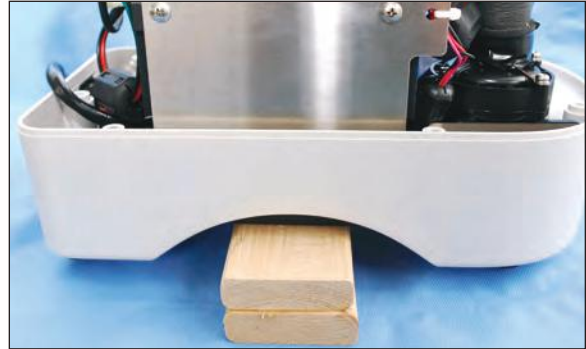

Figure 137 - Step 4 Raise up off table

5. Place the TE brackets over the fan guard screws.

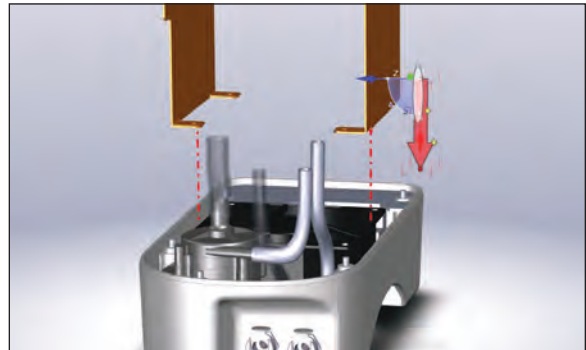

Figure 138 - Step 5 Install brackets

6. Place the fan motor over the TE brackets. The arrow showing air flow direction must point toward the interior of the device.

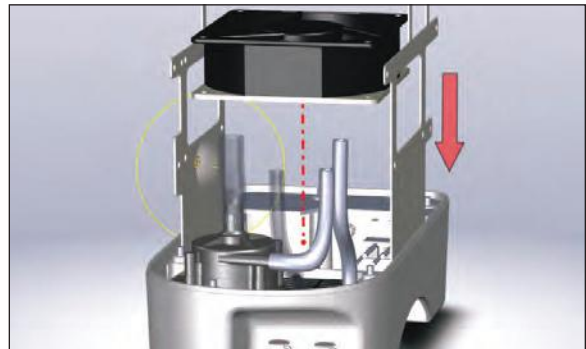

Figure 139 - Step 6 Place fan over TE brackets on fan guard screws

Service

Electri-Cool II Model 767

7. Position the fan wires (Figure 140).
8. Follow instructions for section 35.2 Fan Guard Installation, on page 110.
9. Follow instructions for section 33.2 TE Module Installation, on page 99.
10. Follow instructions for section 32.2 Power Supply Installation, on page 93.
11. Follow instructions for section 31.2 Control Board Installation, on page 89.
12. Follow instructions for section 21.2 Front Enclosure Installation, on page 45.
13. Power on the unit and perform a leak test (section 18.2 on page 28).
14. Remove any kinks in the water tubing.
15. Determine if the fan is blowing correctly to the inside of the device by placing a piece of paper below the filter inlet.
16. Perform the maintenance as required by the Preventive Maintenance Inspection Sheet in Table 5.
17. Follow instructions for section 20.2 Rear Enclosure and Reservoir Lid Installation, on page 41.



Figure 140 - Step 7 Wire position



Fan Guard & Filter

35.0 Fan Guard Replacement



CAUTION: Working with electronic boards, plugs, and cables requires delicate handling. Proper Electrostatic Discharge (ESD) procedures should be followed during replacement of any electronic board. Failure to do so may result in damage to the board.

Tools:

- #2 Phillips screwdriver
- Long small tip slotted screwdriver
- Needle-nose pliers

Parts provided:

- Fan guard with Manufacturer Filter*

*A Gentherm filter is not supplied and must be ordered separately.



Tools

35.1 Fan Guard Removal

1. Follow instructions for section 20.1 Rear Enclosure and Reservoir Lid Removal, on page 39.
2. Follow instructions for section 21.0 Front Enclosure Replacement, on page 43.
3. Use the slotted tip screwdriver to pry the filter retainer from the base of the unit. (Figure 141).

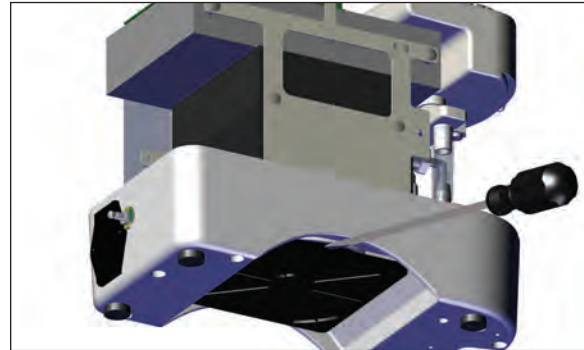

Figure 141 - Step 3 Pry filter cover off

4. Remove the plastic shield and set it aside (Figure 142).

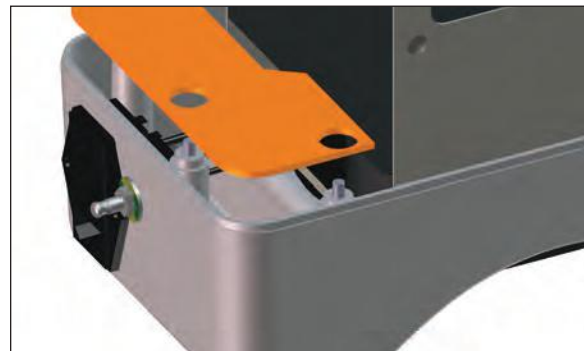

Figure 142 - Step 4 Remove shield

5. Set the unit on its feet with one corner hanging over the edge of a secure work surface. Use the #2 Phillips screwdriver from beneath the unit to remove the four screws and Keps nuts that secure the fan motor and thermoelectric subassembly to the fan guard. Use the slotted screwdriver against a flat side of the Keps nut to hold it stationary while unscrewing the screw (Figure 143).

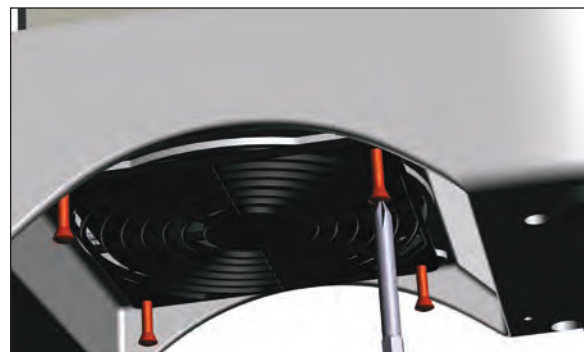

Figure 143 - Step 5 Unscrew four screws

Operation & Service Manual

6. Remove screw and nut #1.

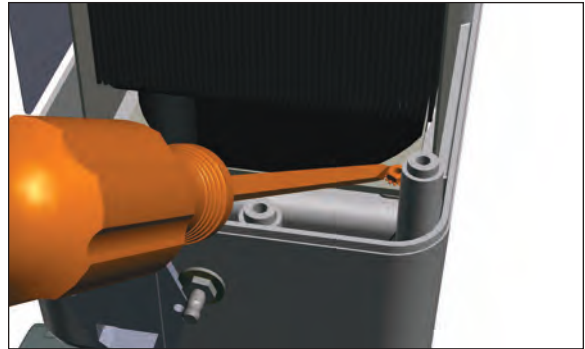

Figure 144 - Step 6 Remove Keps nut #1

7. Remove screw and nut #2.

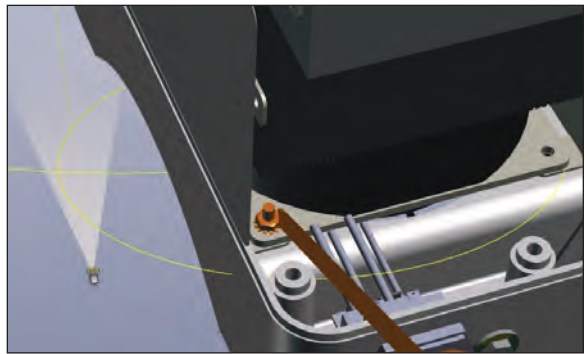

Figure 145 - Step 7 Remove Keps nut #2

8. Remove screw and nut #3.

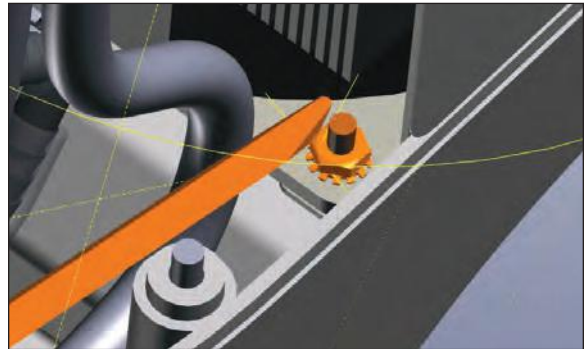

Figure 146 - Step 8 Remove Keps nut #3

Service

Electri-Cool II Model 767

9. Remove screw and nut #4.
10. Dispose of the used fan guard, the filter and the filter retainer according to facility protocols.



Figure 147 - Step 9 Remove Keps nut #4

Operation & Service Manual

35.2 Fan Guard Installation

Screws should be inserted and tightened in the order shown.

1. Insert the first #8-32 x 1" oval-head screw into the fan guard screw holes. The screw should point in the opposite direction from the filter. Insert them in the order shown for best results (Figure 148). Use the Phillips screwdriver to tighten the screw while holding the Keps nut with the slotted screwdriver. Screw #3 shown.
2. Insert screw #2, place a Keps nut on top, and tighten.
3. Insert screw #3 through the fan guard and mounting holes on the base enclosure. Use the slotted screwdriver to hold the nut in position, then place the Keps nut over the top and slowly thread the screw into the nut (Figure 149).
4. Insert screw #4 through the fan guard mounting holes ("Figure 150 - Step 4 Insert screw #4").

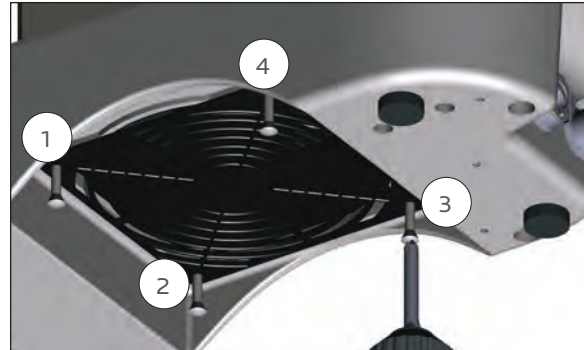

Figure 148 - Step 1 Insert screws in order.

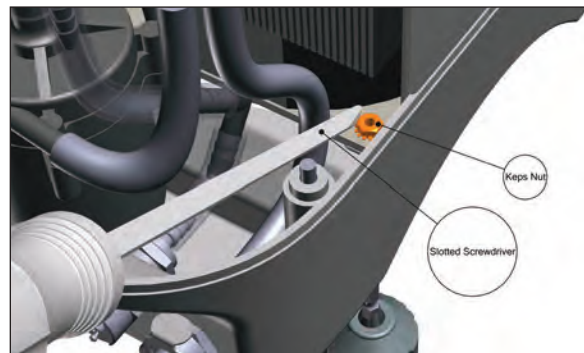

Figure 149 - Step 3 Hold Keps nut #3



Figure 150 - Step 4 Insert screw #4

Service

Electri-Cool II Model 767

5. Hold it in place in the same manner as screw #3, and thread the screw into the nut (Figure 151).



Figure 151 - Step 5 Hold Keps nut #4

6. Place the plastic shield in position (Figure 152).

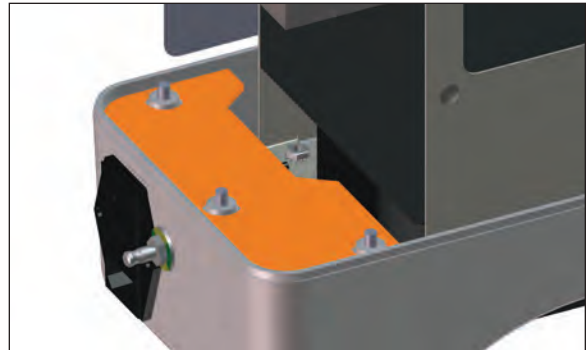

Figure 152 - Step 6 Place plastic shield in position

7. Place the Gentherm air filter inside the filter retainer recess.



Figure 153 - Step 2 Place filter into retainer

Operation & Service Manual

8. Place the filter retainer with filter into position against the fan guard. Press firmly on all four sides until it snaps into place (Figure 154).
9. Follow instructions for section 21.2 Front Enclosure Installation, on page 45.
10. Check for leaks with power on. See section 18.2 on page 28.
11. Check for kinks in the water tubing.
12. Determine if the fan is blowing correctly to the inside of the device by placing a piece of paper below the filter inlet.
13. Perform the maintenance as defined in the “Preventive Maintenance Inspection Sheet” on page 117.
14. Follow instructions for section 20.2 Rear Enclosure and Reservoir Lid Installation, on page 41.



Figure 154 - Step 8 Re-attach filter retianer

36.0 Specifications

| Physical | |
|---|---|
| Approximate Dimensions: | 30.5 cm (12 in.) Width 15.2 cm (6 in.) Depth 30.5 cm (12 in.) Height |
| Approximate Weight: | 5.9 kg (13 lb.) |
| Approximate Hose Length: | 1.83 m (6 ft.) |
| Filtration: | |
| Outer Construction: Portability: Molded carrying handle Connectors: Quick-Connect, Self Sealing | Case material: G.E Cycoloy 6600 Plastic, Grey |
| Electrical System | |
| Maximum Current: | 3.5 Amps |
| Heating power: | 650 W |
| 115V Cord: | 100 – 240 VAC, 50 -60Hz |
| Fuse: | 5 Amp, Rated at 250Vm 5mm x 20mm, Time Delay. 2x Line and Neutral |
| Power Cord: | 115V & 100V – 3 Conductor, 16/18 AWG, 10' Molded Hospital Grade Plug. 230V – 3 x 1mm, 10A |
| Leakage Current: | Under 300 Microamps |
| Shock Protection Type: | Class 1 |
| Degree of Shock Protection: | Type B Applied Part |
| Circulating System | |
| Reservoir Capacity | 400ml (11.84 fl. oz.) |
| Reservoir Fluid | Sterile water or water that has been passed through a filter less than or equal to 0.22 microns |
| Fill Cap: | Vented |
| Flow Rate (through pad): | 68 LPH (18 GPH) |
| Water level indicator: | Yes |
| Low Water Cut-off Switch: | Yes |
| Storage: | Dry |
| Degree of Protection: | IPX0 Rated Equipment |

Operation & Service Manual

Safety System

| | |
|------------------------------|------------------------|
| Low Water | 200ml (6.76 fl. oz.) |
| Low Temperature | 2.2°C (36.0°F) |
| Warning Lights | Low Temp and Low Water |
| Audible Indicators: | Low Temp and Low Water |
| Classified to UL 60601-1: | Yes |
| Classified to IEC 60601-1-2: | Yes |

36.1 Expected Service Life

The Electri-Cool II has a maximum lifetime of 5 years, when used with sterile water or water that has been passed through a filter less than or equal to 0.22 microns.

| Guidance and manufacturer's declaration – electromagnetic immunity | | | |
|--|-------------------------------------|------------------|--|
| <p>The Electri-Cool® II system is intended for use in the electromagnetic environment specified below. The customer or the user of the Electri-Cool® II system should assure that it is used in such an environment.</p> | | | |
| Immunity test | IEC 60601 test level | Compliance level | Electromagnetic environment - guidance |
| <p>Conducted RF IEC 61000-4-6</p> | <p>3 Vrms 150 kHz to 80 MHz</p> | <p>3 Vrms</p> | <p>Portable and mobile RF communications equipment should be used no closer to any part of the Electri-Cool® II system, including cables, than the recommended separation distance calculated from the equation applicable to the frequency of the transmitter.</p> <p>Recommended separation distance</p> $d = 1,2 \rightarrow P$ |
| <p>Radiated RF IEC 61000-4-3</p> | <p>3 V/m 80 MHz to 2,5 GHz</p> | <p>3 V/m</p> | |
| <p>Where P is the maximum output power rating of the transmitter in watts (W) according to the transmitter manufacturer and d is the recommended separation distance in meters (m).</p> <p>Field strengths from fixed RF transmitters, as determined by an electromagnetic site survey,^a should be less than the compliance level in each frequency range.^b</p> <p>Interference may occur in the vicinity of equipment marked with the following symbol:</p> | | | |
| | | |  |

Guidance and manufacturer's declaration – electromagnetic immunity

Note 1: At 80 MHz and 800 MHz, the higher frequency range applies.

Note 2: These guidelines may not apply in all situations. Electromagnetic propagation is affected by absorption and reflection from structures, objects and people.

a Field strengths from fixed transmitters, such as base stations for radio (cellular/cordless) telephones and land mobile radios, amateur radio, AM and FM radio broadcast and TV broadcast cannot be predicated theoretically with accuracy. To assess the electromagnetic environment due to fixed RF transmitters, an electromagnetic site survey should be considered. If the measure field strength in the location in which the Electri-Cool® II system is used exceeds the applicable RF compliance level above, the Electri-Cool® II system should be observed to verify normal operation. If abnormal performance is observed, additional measures may be necessary, such as re-orienting or relocating the Electri-Cool® II system.

b Over the frequency range 150 kHz to 80 MHz, field strengths should be less than 3 V/m.

Recommended separation distances between portable and mobile RF communications equipment and the Electri-Cool® II system

The Electri-Cool® II system is intended for use in an electromagnetic environment in which radiated RF disturbances are controlled. The customer or the user of the Electri-Cool® II system can help prevent electromagnetic interference by maintaining a minimum distance between portable and mobile RF communications equipment (transmitters) and the Electri-Cool® II system as recommended below, according to the maximum output power of the communications equipment.

| Rated maximum output power of transmitter W | Separation distance according to frequency of transmitter m | | |
|--|--|--|---|
| | 150 kHz to 80 MHz $d = 1,2 \rightarrow P$ | 80 MHz to 800 MHz $d = 1,2 \rightarrow P$ | 800 MHz to 2,5 GHz $d = 2,3 \rightarrow P$ |
| 0,01 | 0,12 | 0,12 | 0,23 |
| 0,1 | 0,38 | 0,38 | 0,73 |
| 1 | 1,2 | 1,2 | 2,3 |
| 10 | 3,8 | 3,8 | 7,3 |
| 100 | 12 | 12 | 23 |

For transmitters rated at a maximum output power not listed above, the recommended separation distance (d) in meters (m) can be estimated using the equation applicable to the frequency of the transmitter, where (P) is the maximum output power rating of the transmitter in watts (W) according to the transmitter manufacturer.

Note 1: At 80 MHz and 800 MHz, the separation distance for the higher frequency range applies.

Note 2: These guidelines may not apply in all situations. Electromagnetic propagation is affected by absorption and reflection from structures, objects and people.

Operation & Service Manual

36.2 Replacement Parts

All replacement parts for the Electri-Cool® II can be found below and must be purchased from Gentherm.

Service is intended to be performed by a biomedical technician.

The Electri-Cool® II must be turned OFF and the power cord must be unplugged before replacing any parts. The Electri-Cool® II system is isolated from the mains power supply by unplugging the power cord at the Electri-Cool® II or at the outlet.

The exploded view of the Electri-Cool® II (Figure 6) below can be used to replace parts. Replacement parts should be installed in the reverse order of removal unless instructions specify otherwise.

| Item No. | Description | Illustration |
|----------|--|-------------------|
| 1 | Bracket, Pump | Shown in Figure 6 |
| 2 | Lug Ground, Euro | Shown in Figure 6 |
| 3 | Ground Lug Washer, Green/Yellow | Shown in Figure 6 |
| 4 | Power Cord, 2.5 meters, 115V Power Cord, 2.5 meters, 230/240V | Not shown |
| 5 | Fuse | Shown in Figure 6 |
| 6 | Power Supply | Shown in Figure 6 |
| 7 | Control Board | Shown in Figure 6 |
| 8 | Float Switch | Shown in Figure 6 |
| 9 | TE Module | Shown in Figure 6 |
| 10 | Fan Guard | Shown in Figure 6 |
| 11 | Fan Motor | Shown in Figure 6 |
| 12 | Pump | Shown in Figure 6 |
| 13 | Insulation Tubing, 3/8" ID x 1/8 W | Shown in Figure 6 |
| 14 | Reservoir | Shown in Figure 6 |
| 15 | Reservoir Lid | Shown in Figure 6 |
| 16 | Enclosure Bottom | Shown in Figure 6 |
| 17 | Side Enclosure Front | Shown in Figure 6 |
| 18 | Side Enclosure Back | Shown in Figure 6 |
| 19 | Panel Mount Coupling | Shown in Figure 6 |
| 20 | Reservoir Collar | Shown in Figure 6 |
| 21 | 18" Velcro Strap | Not shown |
| 22 | PVC Tubing, 12 mm ID x 16 mm OD | Shown in Figure 6 |
| 23 | Rubber Feet | Shown in Figure 6 |
| 24 | Carton | Not shown |
| 25 | Air Filter | Shown in Figure 6 |

| Item No. | Description | Illustration |
|----------|---|-------------------|
| 26 | Reservoir Insulation | Shown in Figure 6 |
| 27 | Operation Manual | Not shown |
| 28 | Membrane Control Panel | Shown in Figure 6 |
| 29 | Exterior Spec Label | Not shown |
| 30 | Plastic Spacer | Shown in Figure 6 |
| 31 | Screw, 8-32 x $\frac{3}{8}$ " flat head SS | Shown in Figure 6 |
| 32 | 8-32 x 1" Phillips Pan M/S 300 SS | Shown in Figure 6 |
| 33 | Kepnut, 8-32 Zinc | Shown in Figure 6 |
| 34 | Kepnut, Plated M6 | Shown in Figure 6 |
| 35 | #8 internal tooth L/W 410 SS | Not shown |
| 36 | Screw, Filister Head, 10-24 x 3/4" | Shown in Figure 6 |
| 37 | Screw, Plastic 8-32 x 1/4", pan head Phillips | Shown in Figure 6 |
| 38 | Washer, Plastic #8 | Shown in Figure 6 |
| 39 | Wire Harness Assembly | Shown in Figure 6 |
| 40 | $\frac{3}{8}$ " Insulation Tubing | Shown in Figure 6 |
| 41 | PVC Tubing $\frac{3}{8}$ " ID x 3/8" OD Clear | Shown in Figure 6 |
| 42 | Not Used | |
| 43 | 6 foot Insulated hose | Not shown |
| 44 | Barbed Elbow, 25 x 25 | Shown in Figure 6 |
| 45 | Fuse Holder | Shown in Figure 6 |
| 46 | EMI Suppressor Core, .680 | Not shown |
| 47 | EMI Suppressor Core, .993 | Not shown |
| 48 | Exterior Logo Label | Shown in Figure 6 |
| 49 | Power Entry Shroud | Shown in Figure 6 |

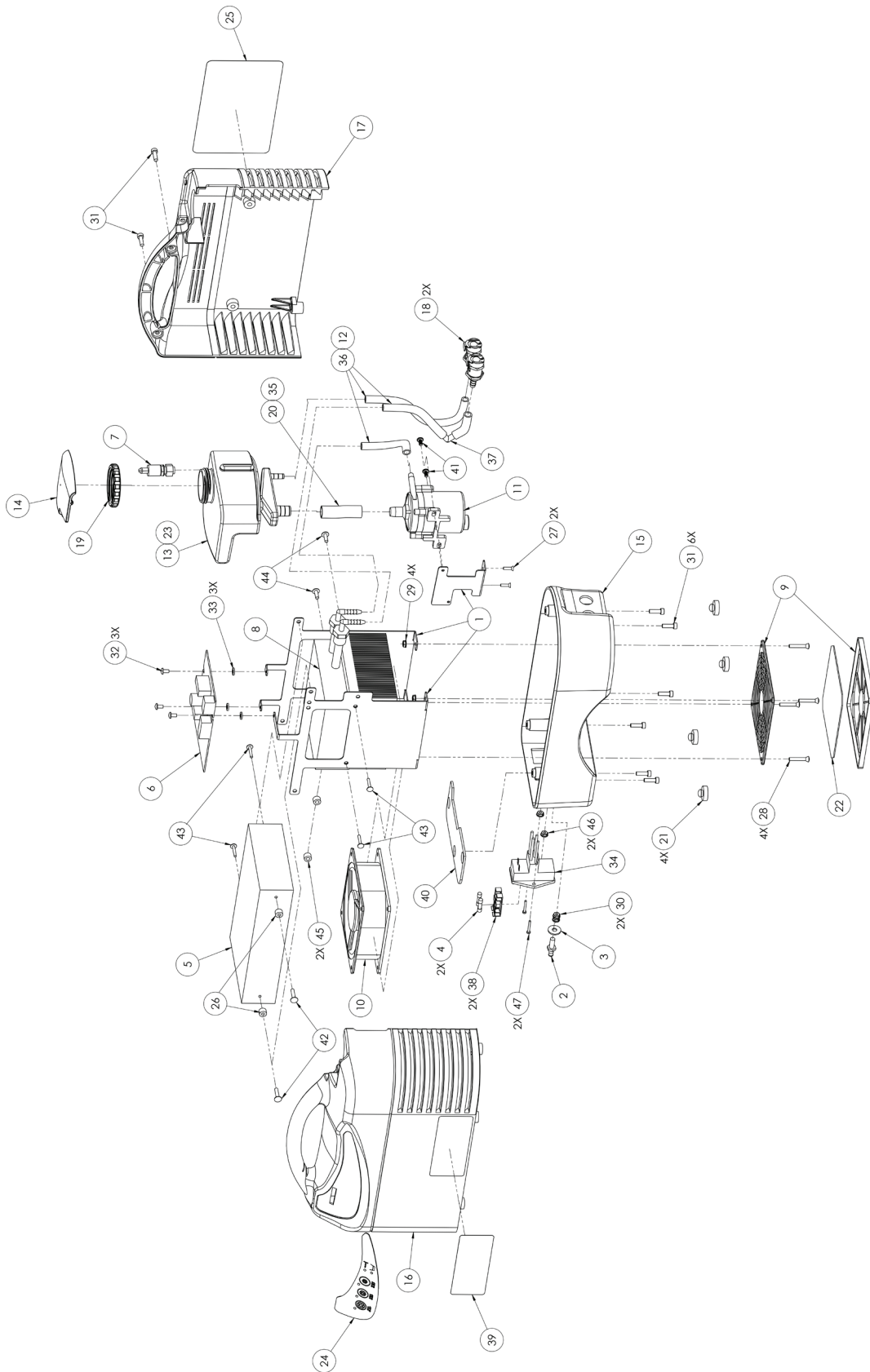

Figure 156 - Exploded view

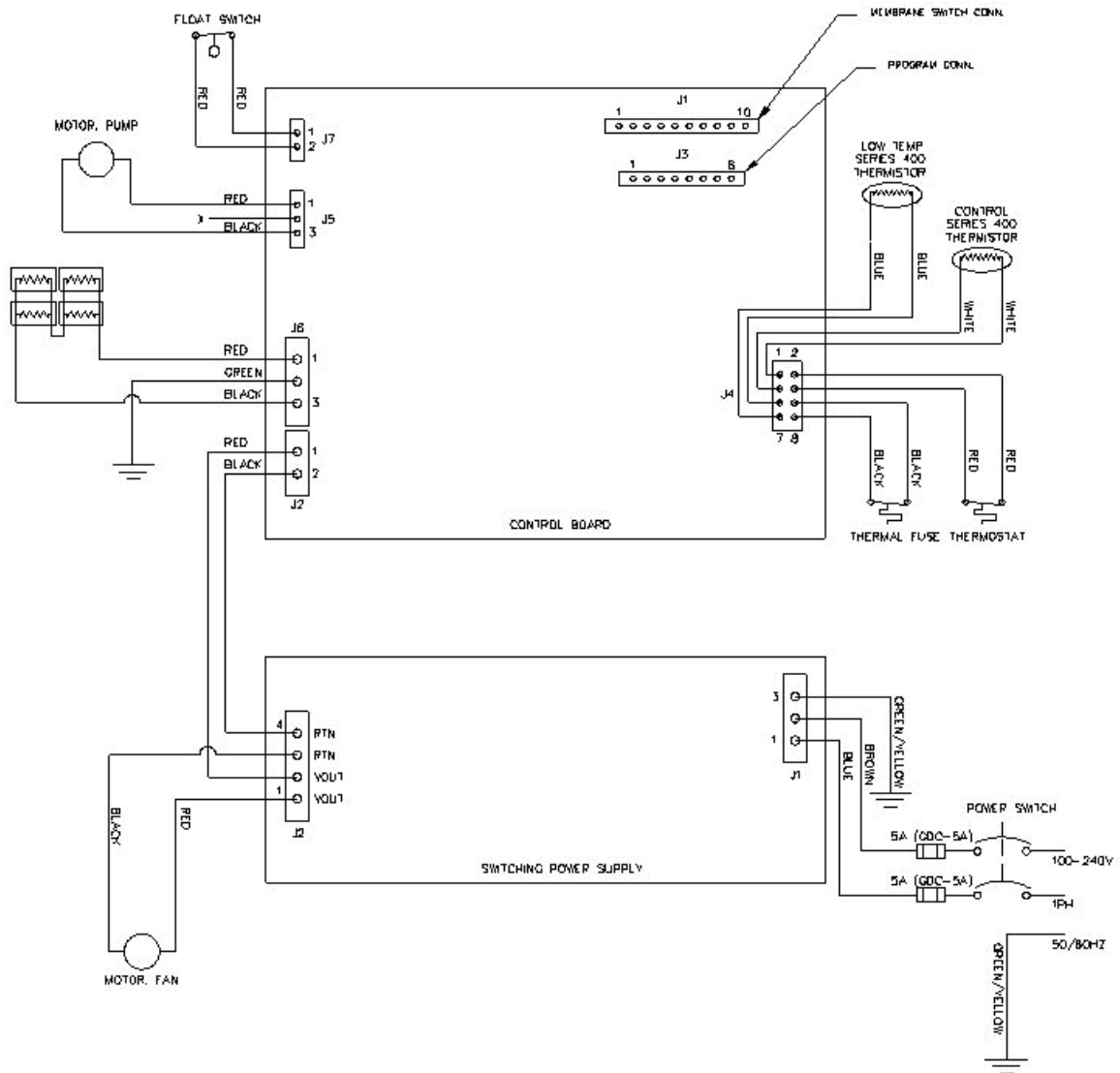

Figure 157 - Wiring Schematic

Operation & Service Manual

37.0 Fluid Circuit Disinfection/Dry Storage Procedure

Quarterly, at a minimum, the FLUID CIRCUIT DISINFECTION/DRY STORAGE PROCEDURE, listed below, should be conducted.

CAUTION: For safe handling and use of chemicals, follow manufacturer guidelines for cleaning.

37.1 Draining the Electri-Cool II

See section 15.0 Draining the Reservoir, on page 22.

Always drain the Electri-Cool® II to a sanitary drain because bio-contaminants may be present in the unit's water supply.

37.2 Chemical Cleaning Circulation Chart

| UNIT | MODE | TEMPERATURE | CLEANING AGENT | DURATION |
|------------------|---------|------------------------------|----------------|------------|
| Electri-Cool® II | Cooling | 11°C - 13°C (51°F - 55°F) | Bleach | 5 Minutes |
| | | | Maranon H | 5 Minutes |
| | | | Gigasept FF | 15 Minutes |

37.2.1 Disinfection/Dry Storage Procedure

The following procedure disinfects the fluid circuit in the Electri-Cool II.

Required tools and supplies:

- Household bleach
- Sterile water or water that has been passed through a filter less than or equal to 0.22 microns
- Appropriate AC electrical power.

Procedure:

1. Turn the unit off ("O" position).
2. Drain the water from the reservoir by tipping the unit forward over a sanitary drain.
3. Fill the reservoir with the appropriate amount of solution shown in the chart below.

| Household Bleach (United States only) | Water |
|---------------------------------------|-----------------|
| 29 Milliliters | 321 Milliliters |

| Gigasept FF (not available in the US) | Water |
|--|-----------------|
| 35 Milliliters (Product of Schulke & Mayr) | 315 Milliliters |
| 29 Milliliters of Maranon H (Product of Ecolab) | 321 Milliliters |

4. Turn the unit on and circulate for 5 minutes.
5. Drain the unit as instructed in Step #1.
6. Rinse the unit three (3) times with sterile water or water that has been passed through a filter less than or equal to 0.22 microns and circulate for 5 minutes.
7. After the third rinse, drain the unit and fill the reservoir with sterile water or water that has been passed through a filter less than or equal to 0.22 microns and circulate.
8. Check the water at the hose with pH strips or other appropriate test method for detecting bleach. If bleach is detected, repeat Steps 4-6.
9. Continue to fill the water reservoir with sterile water or water that has been passed through a filter less than or equal to 0.22 microns.
10. If unit is being placed in dry storage, continue with procedure.
11. When all fluid has been removed from the unit, wipe unit clean.
12. Document unit maintenance.

When returning the unit to service:

- Verify the reservoir is properly filled with sterile water or water that has been passed through a filter less than or equal to 0.22 microns.
- Perform all the checks as described in the respective manual, section 18.1 Flow Test, on page 28, through section 18.7 Water Temperature Low-Limit Thermistor Test, on page 30.

38.0 Appendix A

Table 7. Temperature Equivalent for Resistances at Control & Low Temp Thermistor

| Temp. °C | Ohms | Temp. °C | Ohms | Temp. °C | Ohms | Temp. °C | Ohms |
|----------|------|----------|------|----------|------|----------|------|
| 0.0 | 7355 | 4.0 | 6011 | 8.0 | 4937 | 12.0 | 4074 |
| 0.1 | 7318 | 4.1 | 5982 | 8.1 | 4914 | 12.1 | 4055 |
| 0.2 | 7282 | 4.2 | 5953 | 8.2 | 4890 | 12.2 | 4036 |
| 0.3 | 7245 | 4.3 | 5923 | 8.3 | 4867 | 12.3 | 4018 |
| 0.4 | 7209 | 4.4 | 5894 | 8.4 | 4843 | 12.4 | 3999 |
| 0.5 | 7172 | 4.5 | 5865 | 8.5 | 4820 | 12.5 | 3980 |
| 0.6 | 7135 | 4.6 | 5836 | 8.6 | 4797 | 12.6 | 3961 |
| 0.7 | 7099 | 4.7 | 5807 | 8.7 | 4773 | 12.7 | 3942 |
| 0.8 | 7062 | 4.8 | 5777 | 8.8 | 4750 | 12.8 | 3924 |
| 0.9 | 7026 | 4.9 | 5748 | 8.9 | 4726 | 12.9 | 3905 |
| 1.0 | 6989 | 5.0 | 5719 | 9.0 | 4703 | 13.0 | 3886 |
| 1.1 | 6955 | 5.1 | 5692 | 9.1 | 4681 | 13.1 | 3868 |
| 1.2 | 6920 | 5.2 | 5664 | 9.2 | 4659 | 13.2 | 3850 |
| 1.3 | 6886 | 5.3 | 5637 | 9.3 | 4637 | 13.3 | 3833 |
| 1.4 | 6851 | 5.4 | 5609 | 9.4 | 4615 | 13.4 | 3815 |
| 1.5 | 6817 | 5.5 | 5582 | 9.5 | 4593 | 13.5 | 3797 |
| 1.6 | 6782 | 5.6 | 5554 | 9.6 | 4570 | 13.6 | 3779 |
| 1.7 | 6748 | 5.7 | 5527 | 9.7 | 4548 | 13.7 | 3761 |
| 1.8 | 6713 | 5.8 | 5499 | 9.8 | 4526 | 13.8 | 3744 |
| 1.9 | 6679 | 5.9 | 5472 | 9.9 | 4504 | 13.9 | 3726 |
| 2.0 | 6644 | 6.0 | 5444 | 10.0 | 4482 | 14.0 | 3708 |
| 2.1 | 6612 | 6.1 | 5418 | 10.1 | 4461 | 14.1 | 3691 |
| 2.2 | 6579 | 6.2 | 5392 | 10.2 | 4440 | 14.2 | 3674 |
| 2.3 | 6547 | 6.3 | 5366 | 10.3 | 4419 | 14.3 | 3657 |
| 2.4 | 6514 | 6.4 | 5340 | 10.4 | 4398 | 14.4 | 3640 |
| 2.5 | 6482 | 6.5 | 5314 | 10.5 | 4378 | 14.5 | 3624 |
| 2.6 | 6449 | 6.6 | 5287 | 10.6 | 4357 | 14.6 | 3607 |
| 2.7 | 6417 | 6.7 | 5261 | 10.7 | 4336 | 14.7 | 3590 |
| 2.8 | 6384 | 6.8 | 5235 | 10.8 | 4315 | 14.8 | 3573 |
| 2.9 | 6352 | 6.9 | 5209 | 10.9 | 4294 | 14.9 | 3556 |
| 3.0 | 6319 | 7.0 | 5183 | 11.0 | 4273 | 15.0 | 3539 |
| 3.1 | 6288 | 7.1 | 5158 | 11.1 | 4253 | 15.1 | 3523 |
| 3.2 | 6257 | 7.2 | 5134 | 11.2 | 4233 | 15.2 | 3507 |
| 3.3 | 6227 | 7.3 | 5109 | 11.3 | 4213 | 15.3 | 3491 |

| Temp. °C | Ohms | Temp. °C | Ohms | Temp. °C | Ohms | Temp. °C | Ohms |
|----------|------|----------|------|----------|------|----------|------|
| 3.4 | 6196 | 7.4 | 5085 | 11.4 | 4193 | 15.4 | 3475 |
| 3.5 | 6165 | 7.5 | 5060 | 11.5 | 4174 | 15.5 | 3459 |
| 3.6 | 6134 | 7.6 | 5035 | 11.6 | 4154 | 15.6 | 3442 |
| 3.7 | 6103 | 7.7 | 5011 | 11.7 | 4134 | 15.7 | 3426 |
| 3.8 | 6073 | 7.8 | 4986 | 11.8 | 4114 | 15.8 | 3410 |
| 3.9 | 6042 | 7.9 | 4962 | 11.9 | 4094 | 15.9 | 3394 |

39.0 Approvals

39.1 General Safety and Electrical Safety

- Electromagnetic Compatibility (EMC)
- Tested and passed in accordance with IEC 60601-1-2 EMC requirements



Classified by Underwriters Laboratory Inc.
 ® with respect to Electric Shock, Fire and
 Mechanical Hazards only in accordance with
 UL 60601-1, CAN/GENTHERM-C22.2 No.
 601-1, 5R37

European



In compliance with the Medical Device Directive 93/42/EEC



Gentherm Medical LLC
12011 Mosteller Road
Cincinnati OH 45241 USA
www.gentherm.com

1-800-989-7373

Fax: 1-513-772-9119